

Fluorine 9 F 18.998	Technetium 43 Tc [98]	FIRSTium Gracious 1 Professionalism	Tellurium 52 Te 127.60	Americium 95 Am [243]	Uranium 92 U 238.03	Nitrogen 7 N 14.007	Lithium 3 Li 6.941	Massachusium 6th M Sharon Eagle Robotics Assoc.	Iodine 53 I 126.9	Tellurium 52 Te 127.60	Dedicatium 1st D unlimited. syraweb.org
-------------------------------------	---------------------------------------	--	--	---------------------------------------	-------------------------------------	-------------------------------------	------------------------------------	--	-----------------------------------	--	--

Designing for FTC with TETRIX Hints and Tips

Presented by:
Team Unlimited, FTC0001
ftc0001.org

We acknowledge the efforts and copyrights of FIRST, LEGO Education and LEGO with regards to the contents of this workshop. Without their generosity, the FIRST Tech Challenge would not exist!



Outline

- Introduction - TETRIX 201
- The TETRIX System - designing & building
 - Documentation - notes, diagrams, photos, website
 - Design process - for autonomous and operator control
 - Chassis design - drive-train and drivability
 - Tools for TETRIX & FTC
 - Manipulator design - suitability to the task
 - CAD - for design and documentation
 - Mindstorms NXT microcontroller & sensors
 - Coding environments
- Resources and Summary

Dedication 1st D unlimited, syranweb.org	Tellurium 52 Te 127.60	Iodine 53 I 126.9	Massachusetts 6th M Sharon Eagle Robotics Assoc.	Lithium 3 Li 6.941	Nitrogen 7 N 14.007	Uranium 92 U 238.03	Americium 95 Am [243]	Tellurium 52 Te 127.60	FIRSTium Gracious I Professionalism	Technetium 43 Tc [98]	Fluorine 9 F 18.998
--	---------------------------------	----------------------------	--	-----------------------------	------------------------------	------------------------------	--------------------------------	---------------------------------	--	--------------------------------	------------------------------



Introduction - TETRIX 201

- Goal
 - To expand on the basics of how to build a robot
 - Using the TETRIX System
 - For use in the FIRST Tech Challenge

To contact Team Unlimited:

[website ftc0001.org](http://ftc0001.org) [email syraweb@comcast.net](mailto:syraweb@comcast.net)



Challenges past . . .

Tasks undertaken in competition (so far) . . .

- Climb a step or ramp
- Hang from a bar
- Pickup and place objects, from/to various positions
 - From floor level to far above robot starting height
 - Small to large, light to heavy
 - Objects - balls (small to large), rings, batons, pucks . . .
- Move structures to various locations on field
- End with robot at a designated location
- Have team member perform tasks
- Have the robot “shoot” balls
- Balance the robot

Dedication 1st D unlimited, syranweb.org	Tellurium 52 Te 127.60	Iodine 53 I 126.9	Massachusetts 6th M Sharon Eagle Robotics Assoc.	Lithium 3 Li 6.941	Nitrogen 7 N 14.007	Uranium 92 U 238.03	Americium 95 Am [243]	Tellurium 52 Te 127.60	FIRSTium Gracious I Professionalism	Technetium 43 Tc [98]	Fluorine 9 F 18.998
--	---------------------------------	----------------------------	--	-----------------------------	------------------------------	------------------------------	--------------------------------	---------------------------------	--	--------------------------------	------------------------------



Challenge current . . .

2011-12 FTC Competition

- Pay attention to the rules!
 - The Game Manual (& other documents) is your FTC bible!
 - Important new rulings and clarifications are posted at the official FTC forum (supersedes the Game Manual)
 - The Head Inspector and Head Referee are the final authority at competitions - no appeal
- These sources determine the rules of the game, and the allowable content of your robot - all else is speculation
 - Post forum questions only after you have determined that the info is not already available

Dedication 1st D unlimited, syranweb.org	Tellurium 52 Te 127.60	Iodine 53 I 126.9	Massachusetts 6th M Sharon Eagle Robotics Assoc.	Lithium 3 Li 6.941	Nitrogen 7 N 14.007	Uranium 92 U 238.03	Americium 95 Am [243]	Tellurium 52 Te 127.60	FIRSTium Gracious I Professionalism	Technetium 43 Tc [98]	Fluorine 9 F 18.998
--	---------------------------------	----------------------------	--	-----------------------------	------------------------------	------------------------------	--------------------------------	---------------------------------	--	--------------------------------	------------------------------



Design & Build - Documentation

The Engineering Notebook

- Bound single notebook
- All entries in pen, from each team member
- Each session dated and initialed
- A working document, used continuously and consistently
- Never erase, everything has important, especially the things that didn't work
 - Edison, 1000 ways not to, 1% inspiration
- Key part of judging at Championships
 - Label key pages w/sticky notes to highlight
- We like the BookFactory.org oversize lab notebooks
 - Big enough for full page inserts, expandable bindings
 - One for engineering activities, one for other activities



Design & Build - Documentation

The Engineering Notebook

- Having a designated notebook coordinator helps
- Leave space to insert photos and diagrams
 - Illustrations can clarify more quickly than words
 - Photos of white board during brainstorming
- Drawings - hand diagrams are valuable in design stages
- Use of CAD software for design & documentation
 - PTC Creo/Pro for 3D CAD
 - Alternate - we have used Visio & Maya as well
 - Paste pages into place in notebook
- Photography - digital more convenient
 - Natural for capturing stages of development
 - Also document other team activities

Dedication 1st D unlimited, syracuse.org	Tellurium 52 Te 127.60	Iodine 53 I 126.9	Massachusetts 6th M Sharon Eagle Robotics Assoc.	Lithium 3 Li 6.941	Nitrogen 7 N 14.007	Uranium 92 U 238.03	Americium 95 Am [243]	Tellurium 52 Te 127.60	FIRSTIUM gracious I Professionalism	Technetium 43 Tc [98]	Fluorine 9 F 18.998
--	---------------------------------	----------------------------	--	-----------------------------	------------------------------	------------------------------	--------------------------------	---------------------------------	--	--------------------------------	------------------------------



Design & Build - Documentation

The Electronic Engineering Notebook

- On-line collaboration

- Use tools like PTC Windchill and Dropbox to coordinate
- E-documents, printed and assembled into final notebook
- Print or past photos
- Transparent page sleeves can keep it neat

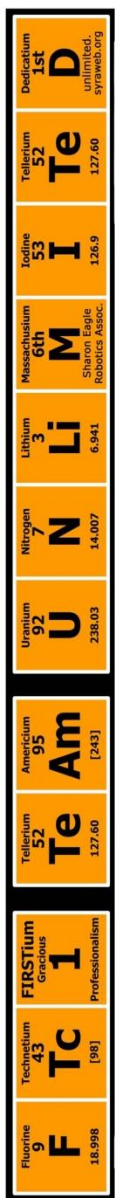

Design & Build - Safety

- Safety glasses are NOT forehead protectors
- Power tools REQUIRE training and supervision
- Parts need to be finished - no ragged/sharp edges
- Safe environment - neat, no obstacles
- Proper attire - footwear, anything long and loose
- First Aid kit at hand
- Remove power BEFORE working on a robot
 - Kill switch, battery disconnection, release mechanical tensioning

Dedication 1st D unlimited, syranweb.org	Tellurium 52 Te 127.60	Iodine 53 I 126.9	Massachusetts 6th M Sharon Eagle Robotics Assoc.	Lithium 3 Li 6.941	Nitrogen 7 N 14.007	Uranium 92 U 238.03	Americium 95 Am [243]	Tellurium 52 Te 127.60	FIRSTium Gracious 1 Professionalism	Technetium 43 Tc [98]	Fluorine 9 F 18.998
--	---------------------------------	----------------------------	--	-----------------------------	------------------------------	------------------------------	--------------------------------	---------------------------------	--	--------------------------------	------------------------------



Design & Build - TETRIX System

Origins of the TETRIX System

- Intended as an enhanced platform for the FIRST Tech Challenge
 - Replaced the Vex Robotic Development System
- LEGO Education (Pitsco) integrates the system
 - Supplies technological education systems to schools
 - Represents LEGO to educational markets
- Components available at a 30% discount to FTC teams
 - <http://parts.ftcrobots.com/store/default.aspx?bhcp=1>



Design & Build - TETRIX System FTC Competition Kit



2012/13 Building for FTC with TETRIX - Hints and Tips Workshop

Dedication 1st D unlimited, syranweb.org	Tellurium 52 Te 127.60	Iodine 53 I 126.9	Massachusetts 6th M Sharon Eagle Robotics Assoc.	Lithium 3 Li 6.941	Nitrogen 7 N 14.007	Uranium 92 U 238.03	Americium 95 Am [243]	Tellurium 52 Te 127.60	FIRSTium gracious 1 Professionalism	Technetium 43 Tc [98]	Fluorine 9 F 18.998
--	---------------------------------	----------------------------	--	-----------------------------	------------------------------	------------------------------	--------------------------------	---------------------------------	--	--------------------------------	------------------------------

Design & Build - TETRIX System 2011 FTC Competition Kit

- **TETRIX® Education Base Set, which includes:**

- Brackets and mounts
- Structural channel and plates
- Structural tubing and hubs
- Wheels and gears and omniwheels
- Battery pack and charger
- Hard Point Connectors for attaching *TETRIX* elements to LEGO Technic elements
- Servos, DC motors, and associated HiTechnic controllers
- Fasteners and tools
- Storage bin
- **NEW TETRIX** Getting Started Printed Guide and DVD

- **LEGO® MINDSTORMS® Education NXT Base Set, which includes:**

- *NXT Intelligent Brick*
- Rechargeable NXT battery and charger
- Servo motors, gears, LEGO Technic beams
- Storage bin

- Install CD & one-year FTC team license for *LabVIEW™* for LEGO MINDSTORMS
- Install CD & one-year team license for PTC *Creo/Pro 3D CAD/CAM* design s/w
- One Logitech joystick controller

\$650 w/LEGO NXT kit, \$450 w/o it, order at team registration

2012/13 Building for FTC with TETRIX - Hints and Tips Workshop

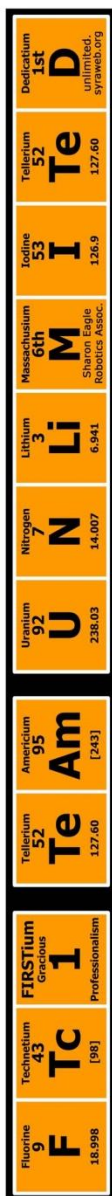

Design & Build - TETRIX System 2012 FTC Resource Kit

- Kit provides more than 40 useful *TETRIX*[™] parts
- Includes the larger gears and longer channel that are not included in the *TETRIX Education Base Set*.
- Includes two additional DC motors and one Logitech joystick controller, and a sturdy plastic storage bin.

\$199, order at
team registration
or at LEGO
Education site



Design & Build - TETRIX System Samantha Wi-Fi for Operator Control



- 802.11b wireless-to-USB adapter for use with the LEGO Mindstorms NXT Brick and Tetrrix in the FTC program.
- Connects through computer Wi-Fi adapter or Wi-Fi router/access point
- LED lights used for status monitoring and troubleshooting.
- Study documentation carefully
 - Critical - power, mounting, and Samostat diagnostic program
 - Your robot won't do well if out of communication

\$65, order (only one) at team registration



Design & Build - Alternate FTC Robotics Kit - Matrix



- New for the 2012-13 season
 - Mostly overseas availability
- Uses LEGO Mindstorms controller & Samantha
 - Alternate motors and controllers
 - Alternate aluminum building components
 - Holes spaced for LEGO bricks

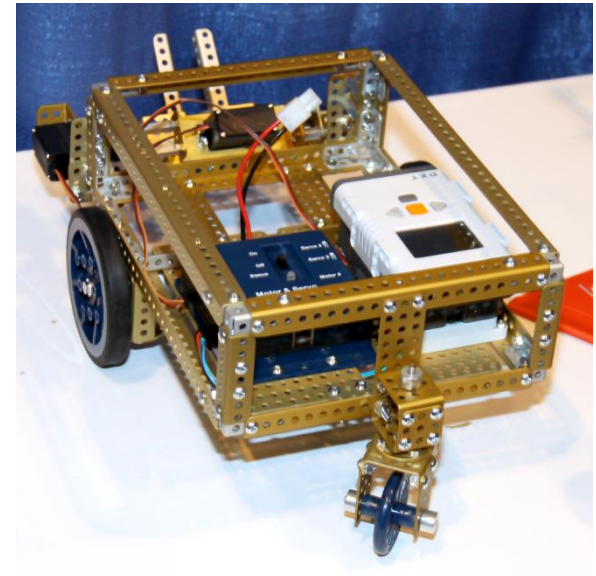
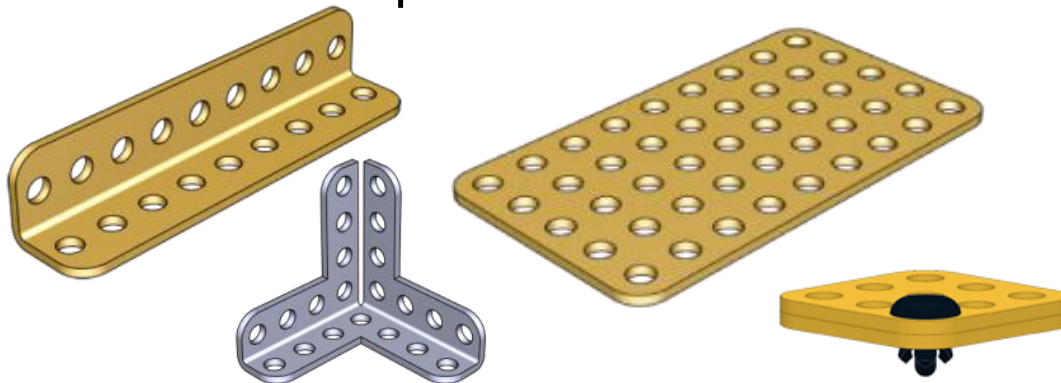

- <http://matrixrobotics.com/>



Robot systems block diagram

- Chassis
- Computer (microcontroller)
- Motors
- Power
- Sensors
- Communications/control

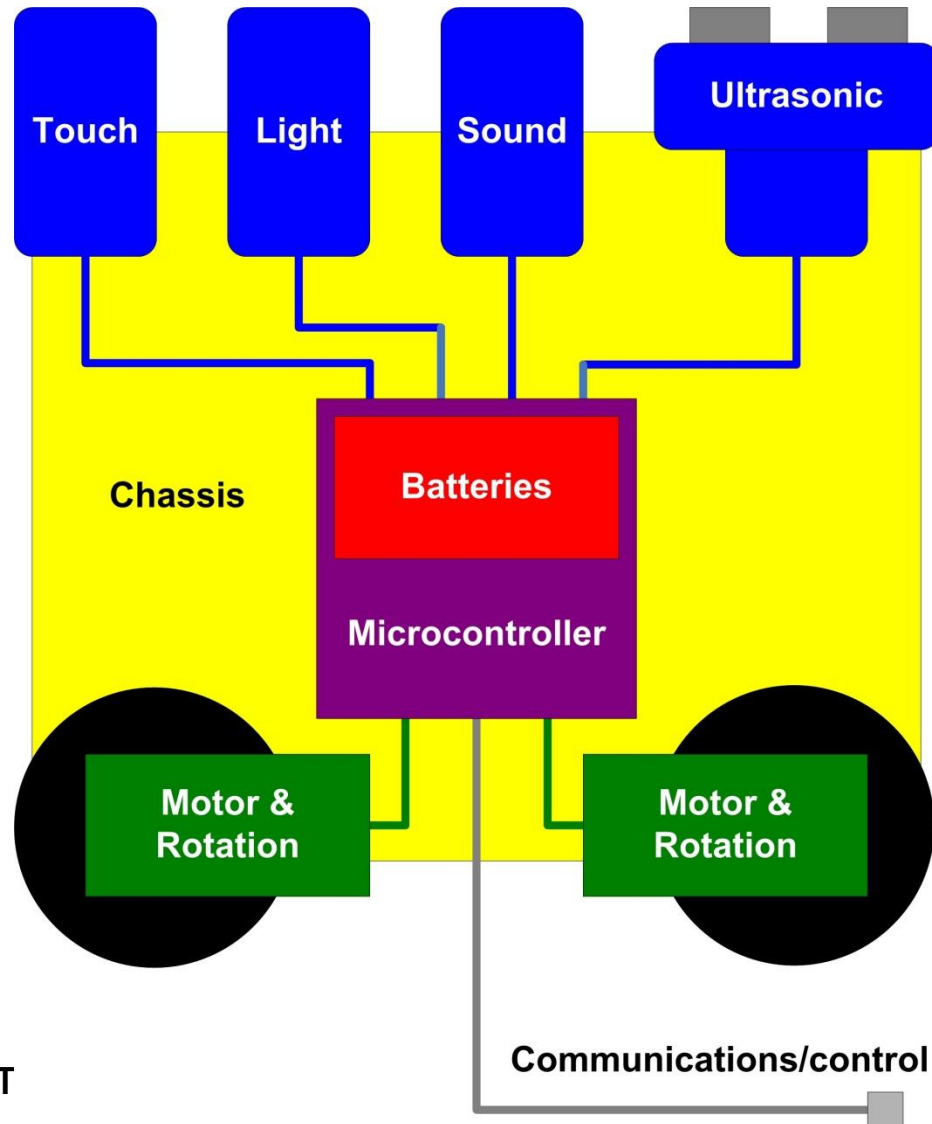

Design & Build - TETRIX System Motor Systems

Dedication 1st D	Tellurium 52 Te	Iodine 53 I	Massachusetts 6th M	Lithium 3 Li	Nitrogen 7 N	Uranium 92 U	Americium 95 Am	Tellurium 52 Te	FIRSTium Gracious 1 I	Technetium 43 Tc	Fluorine 9 F
unlimited, syranweb.org	127.60	126.9	Sharon Eagle Robotics Assoc.	6.941	14.007	238.03	[243]	127.60	Professionalism	[98]	18.998

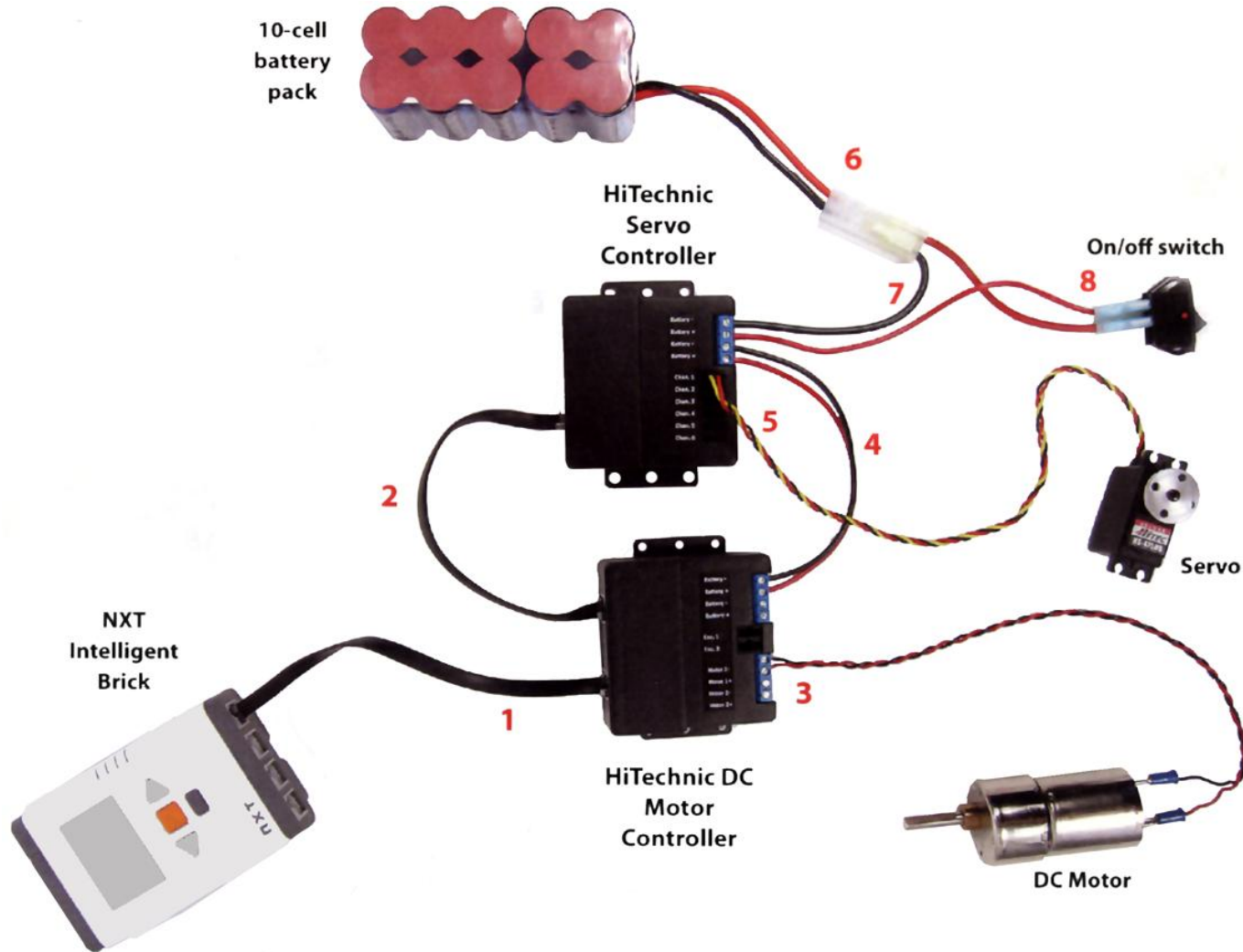

Design & Build - TETRIX System Motor Systems

- NXT Microcontroller
- HiTechnic DC Motor Controller
- DC motor(s)
- HiTechnic Servomotor Controller
- Servomotor(s)
- 10-cell battery pack
- On/Off switch
- Interconnecting wires

Dedication 1st D unlimited, syranweb.org	Tellurium 52 Te 127.60	Iodine 53 I 126.9	Massachusetts 6th M Sharon Eagle Robotics Assoc.	Lithium 3 Li 6.941	Nitrogen 7 N 14.007	Uranium 92 U 238.03	Americium 95 Am [243]	Tellurium 52 Te 127.60	FIRSTium Gracious 1 Professionalism	Technetium 43 Tc [98]	Fluorine 9 F 18.998
--	---------------------------------	----------------------------	--	-----------------------------	------------------------------	------------------------------	--------------------------------	---------------------------------	--	--------------------------------	------------------------------



Design & Build - TETRIX System Servomotor Systems

- Servomotor Controller - up to 6 individual servomotors
- Servo motor throw - 190°
- Chains from NXT/other motor controllers



Design & Build - TETRIX System DC Motor Systems

- DC motor controller - up to 4 DC motors (in pairs)
- Connection pair for PID loop control
- Chains from NXT/other motor controllers



Design & Build - TETRIX System DC motor - direct drive



Dedication 1st D unlimited. syrwanib.org
Tellurium 52 Te 127.60
Iodine 53 I 126.9
Massachusetts 6th M Sharon Eagle Robotics Assoc.
Lithium 3 Li 6.941
Nitrogen 7 N 14.007
Uranium 92 U 238.03
Americium 95 Am [243]
Tellurium 52 Te 127.60
FIRSTium Gracious I Professionalism
Technetium 43 Tc [98]
Fluorine 9 F 18.998



Design & Build - TETRIX System

DC motor - direct drive

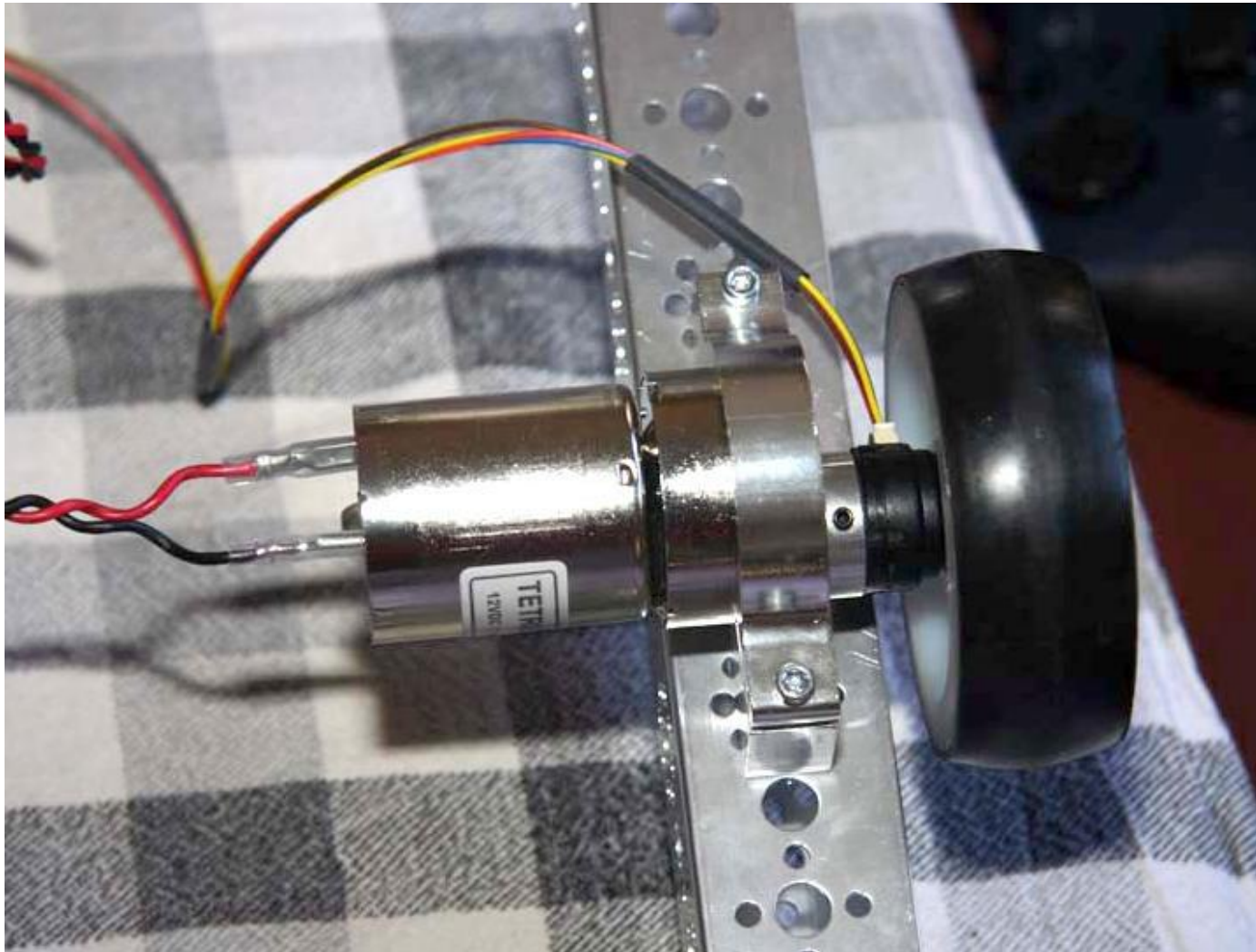

2012/13 Building for FTC with TETRIX - Hints and Tips Workshop



Fluorine 9 F 18.998	Technetium 43 Tc [98]	FIRSTium Gracious 1 I Professionalism	Tellurium 52 Te 127.60	Americium 95 Am [243]	Uranium 92 U 238.03	Nitrogen 7 N 14.007	Lithium 3 Li 6.941	Massachusetts 6th M Sharon Eagle Robotics Assoc.	Iodine 53 I 126.9	Tellurium 52 Te 127.60	Dedicatum 1st D unlimited, syranweb.org
------------------------------	--------------------------------	---	---------------------------------	--------------------------------	------------------------------	------------------------------	-----------------------------	--	----------------------------	---------------------------------	---

Design & Build - TETRIX System LEGO Motor Systems



Dedication 1st D	Tellurium 52 Te	Iodine 53 I	Massachusetts 6th M	Lithium 3 Li	Nitrogen 7 N	Uranium 92 U	Americium 95 Am	Tellurium 52 Te	FIRSTium Gracious I	Technetium 43 Tc	Fluorine 9 F
unlimited, syranweb.org	127.60	126.9	Sharon Eagle Robotics Assoc.	6.941	14.007	238.03	[243]	127.60	Professionalism	[98]	18.998



Design & Build - TETRIX Chassis

Drive train

- Drive-train configuration
 - 2 or 4 motor drive (could be more, not usually)
 - 2, 4 or 6 wheel drive
 - Gearing for torque or speed, as well as power transmission
 - Gearing up for speed can stress gear motors, failures
 - Gearing or sprockets and chain to link motors together

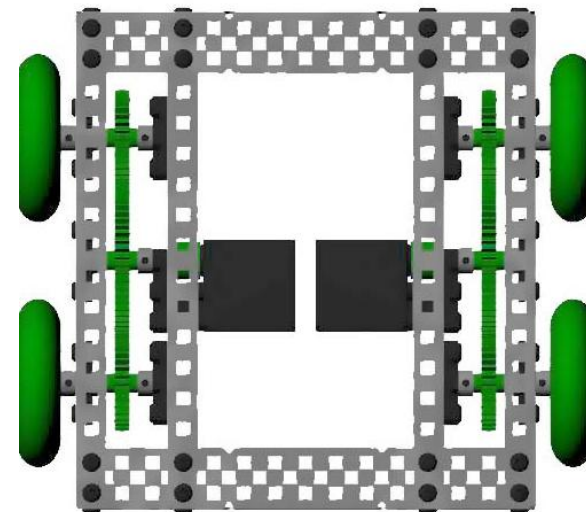
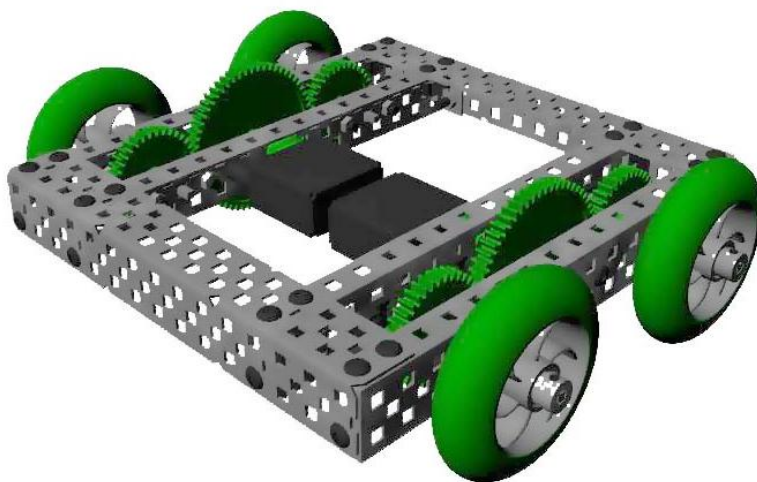

Design & Build - TETRIX Chassis

TETRIX motors & servos

- **TETRIX DC motors** - 152 rpm (full rotation), 300 oz-in. of torque
 - Gearing can adjusting speed/torque ratio
- Most drive designs use differential steering
 - “tank-style”
- **TETRIX Servomotors** rotate 180°, 76 oz-in of torque
 - Gearing to increase torque, decreases speed & throw-angle
- **TETRIX Continuous Rotation Servomotor** rotate full circle, NEW
- **LEGO motors** - 11 RPM (full rotation), 24 oz-in of torque
 - Connect only to LEGO axles
- Pairing motors increases overall drive-train torque
 - Software to control combined motors



Design & Build - TETRIX System Gears & wheels



Dedication 1st D unlimited, syranwab.org	Tellurium 52 Te 127.60	Iodine 53 I 126.9	Massachusetts 6th M Sharon Eagle Robotics Assoc.	Lithium 3 Li 6.941	Nitrogen 7 N 14.007	Uranium 92 U 238.03	Americium 95 Am [243]	Tellurium 52 Te 127.60	FIRSTium Gracious 1 Professionalism	Technetium 43 Tc [98]	Fluorine 9 F 18.998
--	---------------------------------	----------------------------	--	-----------------------------	------------------------------	------------------------------	--------------------------------	---------------------------------	--	--------------------------------	------------------------------



Design & Build - TETRIX System Omni Wheels

- Allow for easy turns, holonomic designs
 - Rollers allow free motion perpendicular to the axis of wheel rotation

Exclusive use of omniwheels results in a robot that gets pushed around easily



Design & Build - TETRIX Chassis Gears

- Available gears - 40, 80 & 120 teeth in aluminum
 - Also LEGO plastic
- Gear trains
 - Gears must space at fixed distances
 - Gear teeth counts (gear x/gear y) result in gearing ratios
 - Power losses at each gear intersection
 - Rotation direction inverted at even gears
 - Multiple stages for large gearing ratio changes

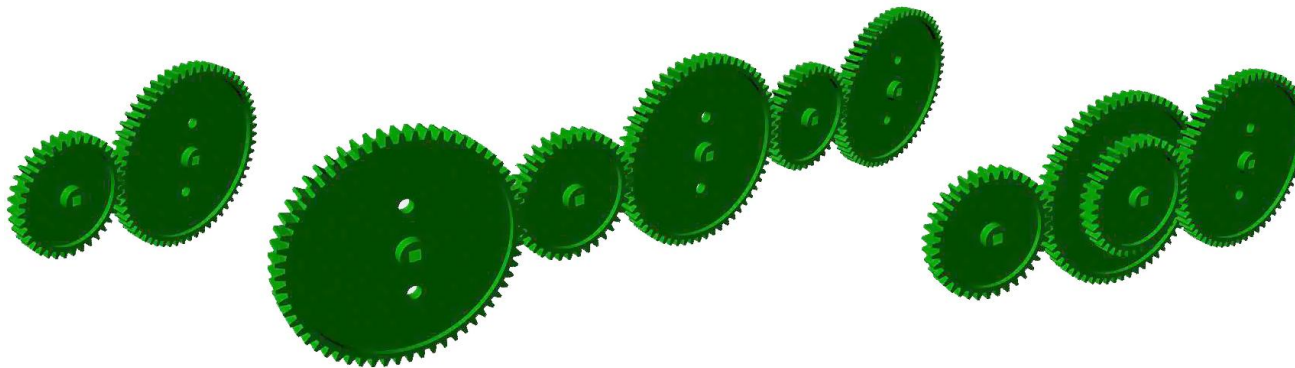

2012/13 Building for FTC with TETRIX - Hints and Tips Workshop

Design & Build - TETRIX Chassis Gears - Torque vs. Speed, Rotation

Dedication 1st D	Tellurium 52 Te	Iodine 53 I	Massachusetts 6th M	Lithium 3 Li	Nitrogen 7 N	Uranium 92 U	Americium 95 Am	Tellurium 52 Te	FIRSTium Gracious 1 I	Technetium 43 Tc	Fluorine 9 F
unlimited, syranweb.org	127.60	126.9	Sharon Eagle Robotics Assoc.	6.941	14.007	238.03	[243]	127.60	Professionalism	[98]	18.998

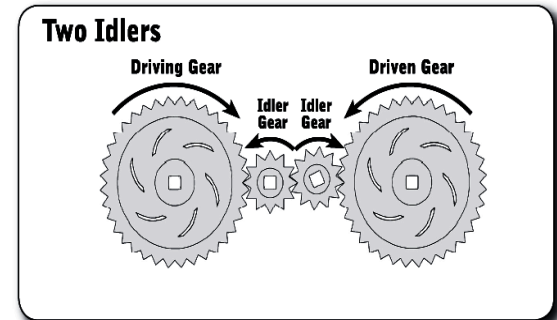
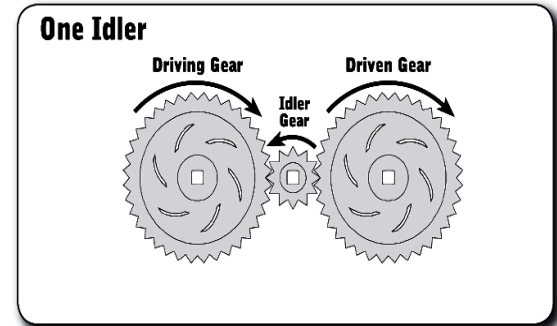
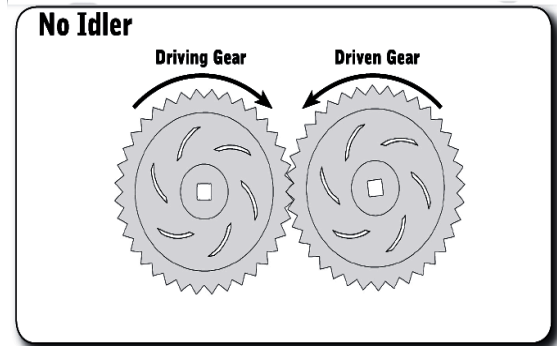
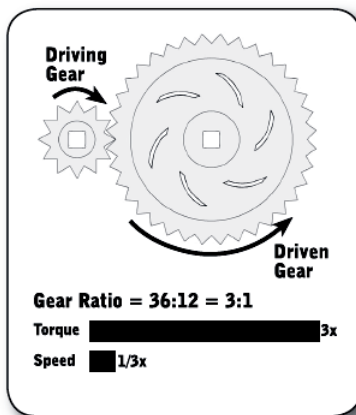
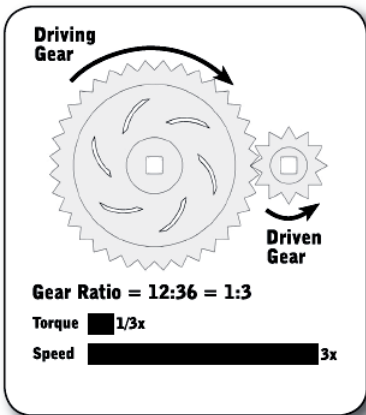
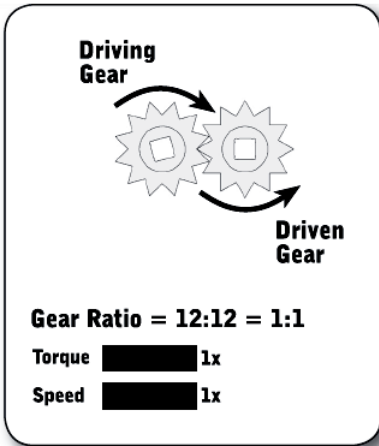

Design & Build - TETRIX Chassis Sprockets & Chain Kit

- TETRIX system enhancement in 2009/10
 - 15, 24 and 32 tooth aluminum sprockets
 - 5 feet of .250 inch steel chain
 - 4 master links
- Chain breaker to cut chain



Design & Build - TETRIX Chassis Sprockets & Chain

- Available sprockets - 15, 24 & 32 tooth
- Chain & sprockets
 - Works like a bicycle chain (connect a loop w/master link)
 - Span any distance - two sprockets, one chain
 - Tensioning important - don't overdo tension
 - Can use idler to tension, under elastic tension, adjustable
 - Sprocket teeth ratios work like gear ratios

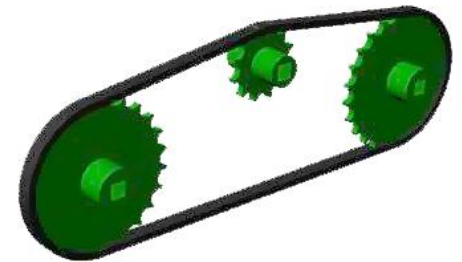
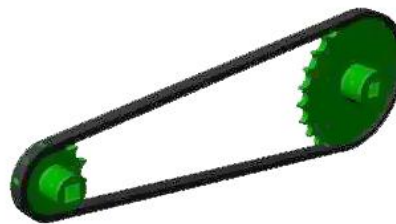
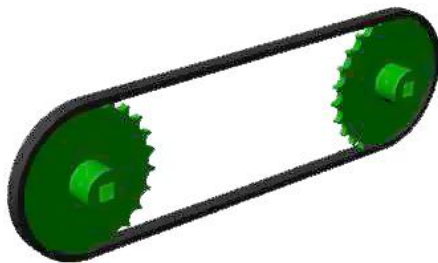

Design & Build - TETRIX Chassis Gears vs. sprockets & chain

- Spanning distances
 - One stage for chain (up to 95% efficient)
 - Multiple stages for gears (each stage up to 85% efficient)
- Adjustment of chain drive-train
 - Don't under- or over-tighten
 - Chain tensioning w/idler sprocket
- Backlash and power loss in gear drive-trains
- Gears only in base TETRIX kit
- Redundancy & reliability
 - Dual chains - run in opposing directions

Dedication 1st D unlimited, syranweb.org	Tellurium 52 Te 127.60	Iodine 53 I 126.9	Massachusetts 6th M Sharon Eagle Robotics Assoc.	Lithium 3 Li 6.941	Nitrogen 7 N 14.007	Uranium 92 U 238.03	Americium 95 Am [243]	Tellurium 52 Te 127.60	FIRSTium Gracious 1 Professionalism	Technetium 43 Tc [98]	Fluorine 9 F 18.998
--	---------------------------------	----------------------------	--	-----------------------------	------------------------------	------------------------------	--------------------------------	---------------------------------	--	--------------------------------	------------------------------



Design & Build - TETRIX System

Servo structural components

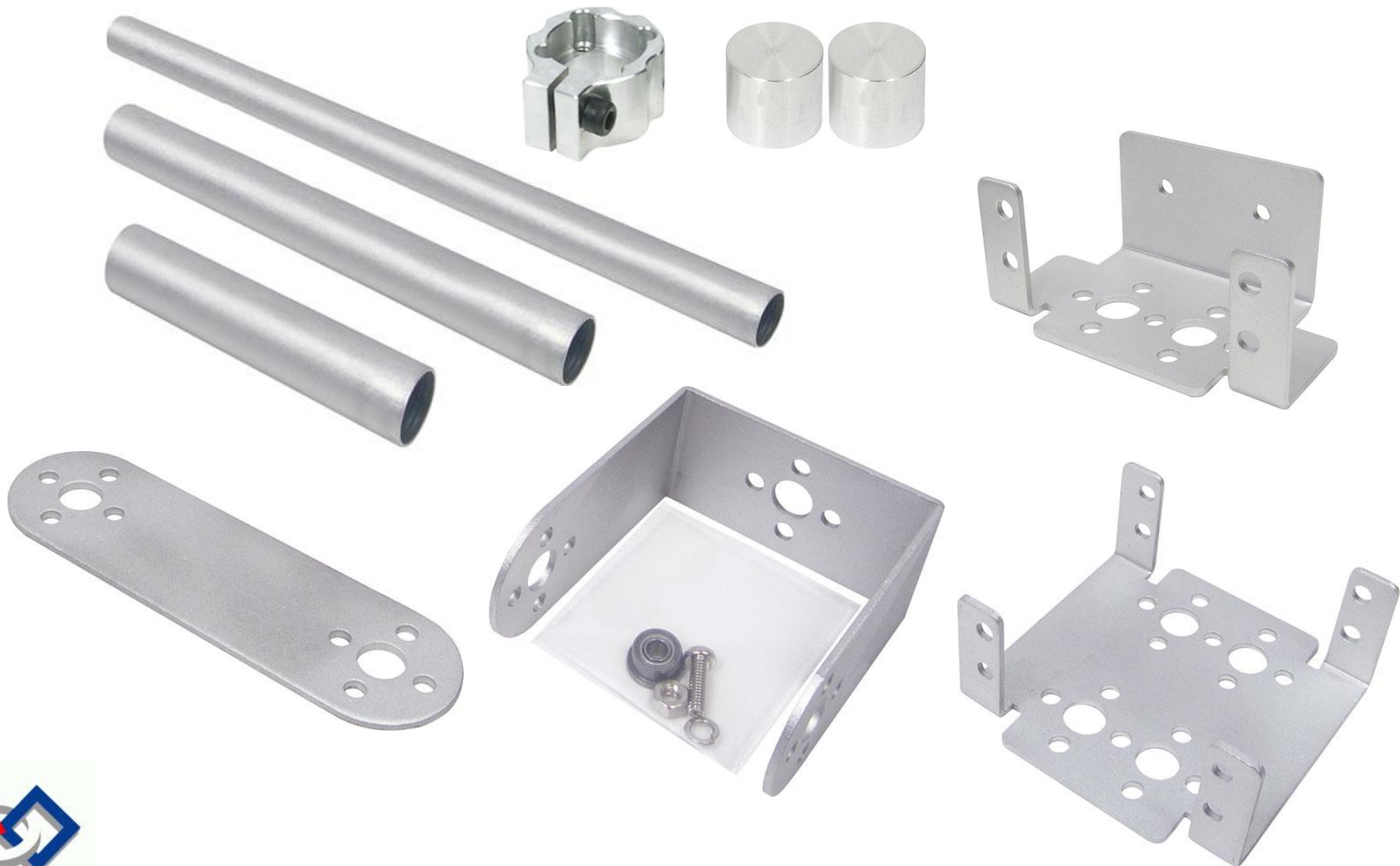

Dedication 1st D unlimited, syranweb.org	Tellurium 52 Te 127.60	Iodine 53 I 126.9	Massachusetts 6th M Sharon Eagle Robotics Assoc.	Lithium 3 Li 6.941	Nitrogen 7 N 14.007	Uranium 92 U 238.03	Americium 95 Am [243]	Tellurium 52 Te 127.60	FIRSTium Gracious 1 Professionalism	Technetium 43 Tc [98]	Fluorine 9 F 18.998
--	---------------------------------	----------------------------	--	-----------------------------	------------------------------	------------------------------	--------------------------------	---------------------------------	--	--------------------------------	------------------------------



Design & Build - TETRIX System

Structural metal and hardware

Dedication 1st D unlimited, syranweb.org	Tellurium 52 Te 127.60	Iodine 53 I 126.9	Massachusetts 6th M Sharon Eagle Robotics Assoc.	Lithium 3 Li 6.941	Nitrogen 7 N 14.007	Uranium 92 U 238.03	Americium 95 Am [243]	Tellurium 52 Te 127.60	FIRSTium gracious I Professionalism	Technetium 43 Tc [98]	Fluorine 9 F 18.998
--	---------------------------------	----------------------------	--	-----------------------------	------------------------------	------------------------------	--------------------------------	---------------------------------	--	--------------------------------	------------------------------

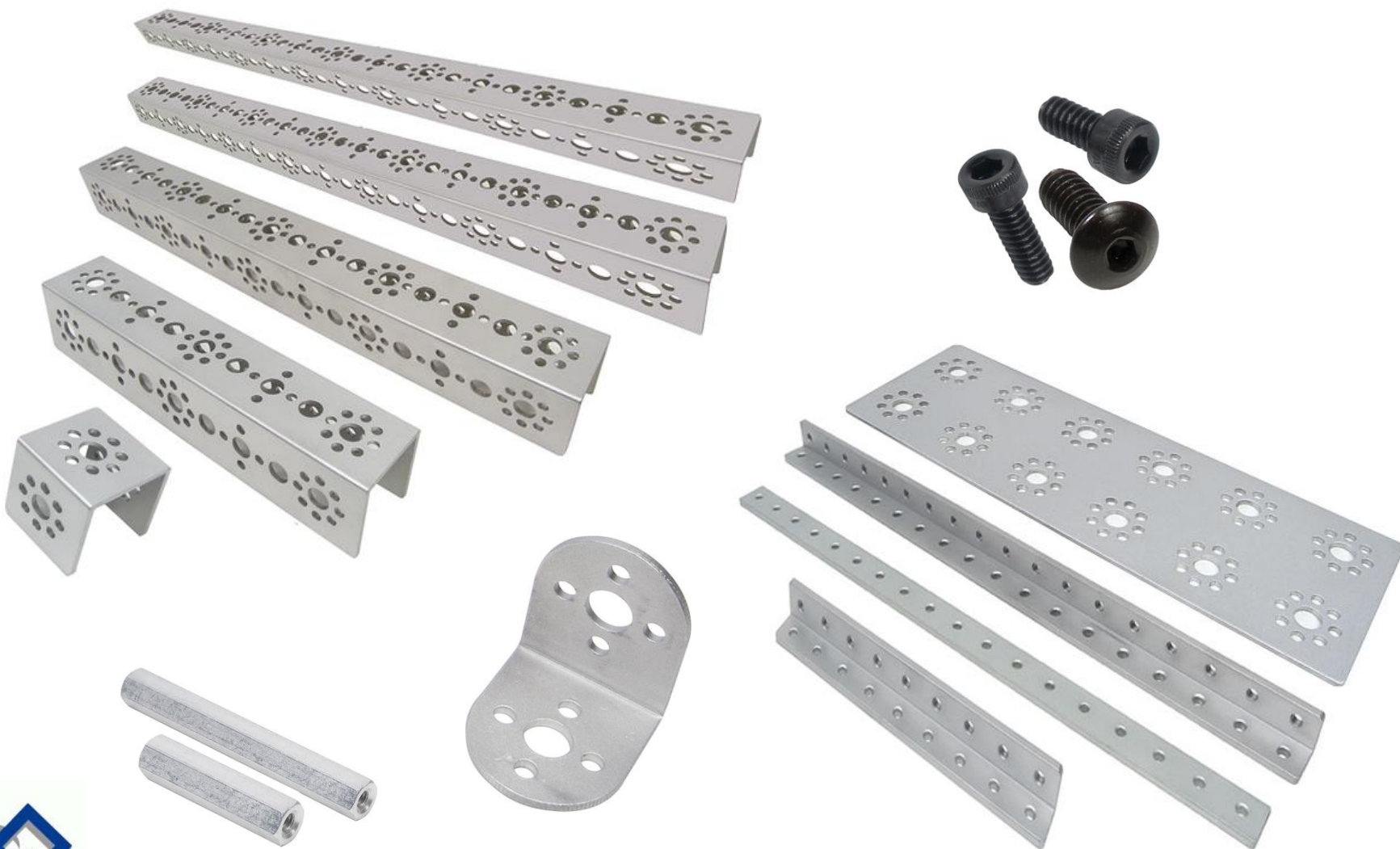

Design & Build - TETRIX System Outside Materials

- Sheet materials
 - New rules allow any materials, in any quantity
 - When using plastic or metal sheets, prototyping with cardboard or foam board saves money
 - Prototyping parts can be used as templates for permanent replacements
- Springs
 - Rubber bands and surgical tubing
 - No pre-formed metal springs
 - Spring materials are allowed now
 - For example: spring steel & piano wire

Dedication 1st D	Tellurium 52 Te	Iodine 53 I	Massachusetts 6th M	Lithium 3 Li	Nitrogen 7 N	Uranium 92 U	Americium 95 Am	Tellurium 52 Te	FIRSTium Gracious 1 I	Technetium 43 Tc	Fluorine 9 F
unlimited, syranweb.org	127.60	126.9	Sharon Eagle Robotics Assoc.	6.941	14.007	238.03	[243]	127.60	Professionalism	[98]	18.998



Design & Build - TETRIX System Outside Materials

- Major material rule changes for 2012-13
 - More materials allowed, with few quantity limits
 - Some pre-formed assemblies allowed
- Raw materials allowed
 - If not pre-processed into functional form, & if available from standard sources (McMaster-Carr, Home Depot, etc)
- Some formed materials allowed
 - Bearings, bushing, fasteners
 - Rope, cord, cable, rubber bands, latex tubing
 - Cable management products, non-slip pad (non-adhesive)
- Miscellaneous materials allowed
 - Lubricants, solder, tape, glue, zip ties (non-metallic)

Dedication 1st D	Tellurium 52 Te	Iodine 53 I	Massachusetts 6th M	Lithium 3 Li	Nitrogen 7 N	Uranium 92 U	Americium 95 Am	Tellurium 52 Te	FIRSTium Gracious 1 I	Technetium 43 Tc	Fluorine 9 F
unlimited, syranweb.org	127.60	126.9	Sharon Eagle Robotics Assoc.	6.941	14.007	238.03	[243]	127.60	Professionalism	[98]	18.998



Design & Build - TETRIX System Outside Materials

- COTS (Commercial Off The Shelf) assemblies not allowed, with the exception of:

- Linear slides
- Non-motorized turntables
- Lead screws & threaded rod, plus compatible nuts
- Servo blocks (ServoCity)
- #25 chain & connector links



Design & Build - TETRIX System Wiring blocks

- Anderson Powerpole connectors and power distribution blocks (as one example)
 - More efficient and reliable DC power connections



Tetrix Resources

- <http://www.usfirst.org/roboticsprograms/ftc/tetrixresources/>
- <http://www.ftcrobotics.com/ftc/>
- <http://www.ftc0001.org/Resources.htm>
- <http://ftcforum.usfirst.org/>
- <http://www.robotc.net/ftc/>
- <http://www.tetrixrobotics.com/ftc/>
- <http://www.ftc0001.org/Resources.htm>
- <http://ftcforum.usfirst.org/>
- <http://www.robotc.net/ftc/>
- By the Pope John XXIII High School Regional Robotics Team

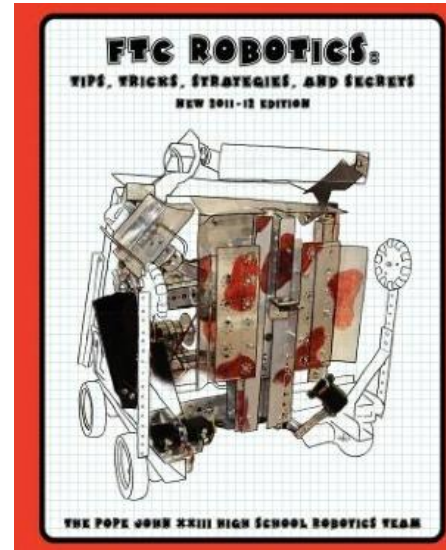

Design & Build - Tools Useful for building

- Wrenches and combination wrenches, vise grips
- Bondhus ball hex driver L-wrenches 10945
 - 7 pc, 5/64-3/16", ball heads allow angle entry up to 15°, rather than just square to the bolt.
- Xcelite series 99 pieces:
 - Regular handle (99-1), stubby (99-3), ratcheting tee (99-4-R)
 - Slotted screwdriver 1/8" (99-125), 3/16" (99-811)
 - Phillips screwdriver #0 (99-820), #1 (99-821)
 - Allen 1/16" (99-21), 5/64" (99-22), 3/32" (99-23), 7/64" (99-764)
 - Driver 4" extension (99-X5)



Design & Build - Tools

Hex drivers for Tetrrix

- Remember - righty, tighty; lefty, loosey
 - Helps to avoid damaging hex heads!
- $1/16''$ ($4/64''$)
 - Axle collar and motor encoder set screws
- $5/64''$
 - Button head cap screws
- $3/32''$ ($6/64''$)
 - Axle and motor shaft hub set screws
- $7/64''$
 - Socket head cap screws



Design & Build - Tools Useful for building

- Cutters and shapers

- Hacksaws (regular & mini)
- Aviation shears (straight)
- Files (flat, for smoothing cut edges)
- Reamer (for enlarging holes)
- Electric hand drill, drill bits & driver bits
- Electric sander & sandpaper
- Electric jigsaw & blades

- Misc.

- Tape Measure
- Steel rulers
- Vises



Design & Build - Tools Useful for building

- Handling additional materials
 - Bending polycarbonate - heat gun
 - Cutting polycarbonate - hacksaw, jigsaw
 - Bending sheet aluminum - bending brake, vise
 - Cutting sheet aluminum - aviation shears, nibbling tool



Design & Build - TETRIX Chassis

Chassis design

- Physical layout

- Chassis usually rectangular

- Short wheelbase & wide body better for turns & side stability
 - Long wheelbase & narrow body better for front-back stability
 - Square chassis a compromise for both

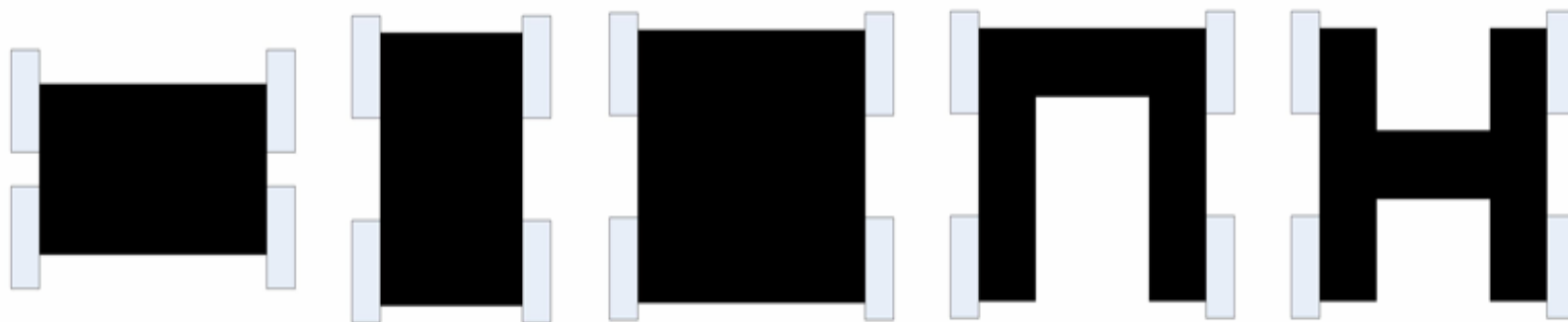

Design & Build - TETRIX Chassis

Chassis design

- Holonomic chassis

- Omniwheels on each corner (usually 3 or 4) driven by independent motors
- By mixing direction of rotation and power by software, can go in any direction without turning
- Tends to lack power and traction, fairly easily pushed

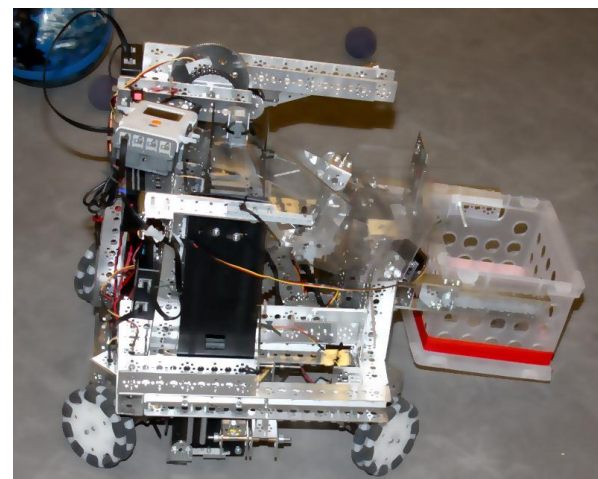
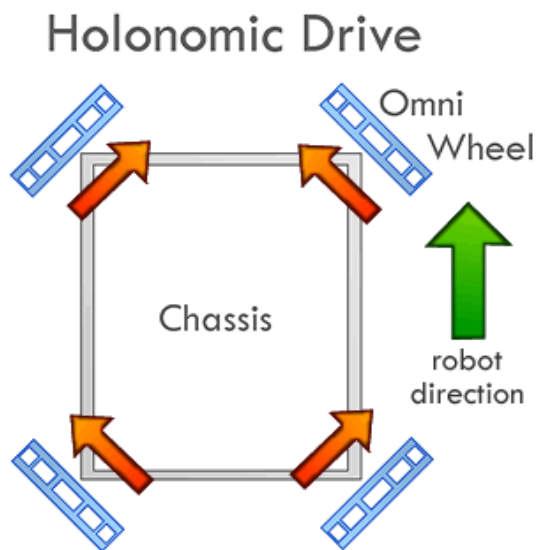

Design & Build - Champions

Characteristics of Champion Robots

- Reliability of robot
- Consistency of performance
- Rugged construction
- KISS (as much as possible)
- Good autonomous mode
- Large size
- Minimal LEGO components

Dedication 1st D unlimited, syranweb.org	Tellurium 52 Te 127.60	Iodine 53 I 126.9	Massachusetts 6th M Sharon Eagle Robotics Assoc.	Lithium 3 Li 6.941	Nitrogen 7 N 14.007	Uranium 92 U 238.03	Americium 95 Am [243]	Tellurium 52 Te 127.60	FIRSTium Gracious 1 Professionalism	Technetium 43 Tc [98]	Fluorine 9 F 18.998
--	---------------------------------	----------------------------	--	-----------------------------	------------------------------	------------------------------	--------------------------------	---------------------------------	--	--------------------------------	------------------------------



Design & Build - TETRIX Chassis

Simple chassis design

- Simple 4 wheel, independent drive motors, ungeared
 - TETRIX tires have very good traction, long wheelbase will resist differential turning

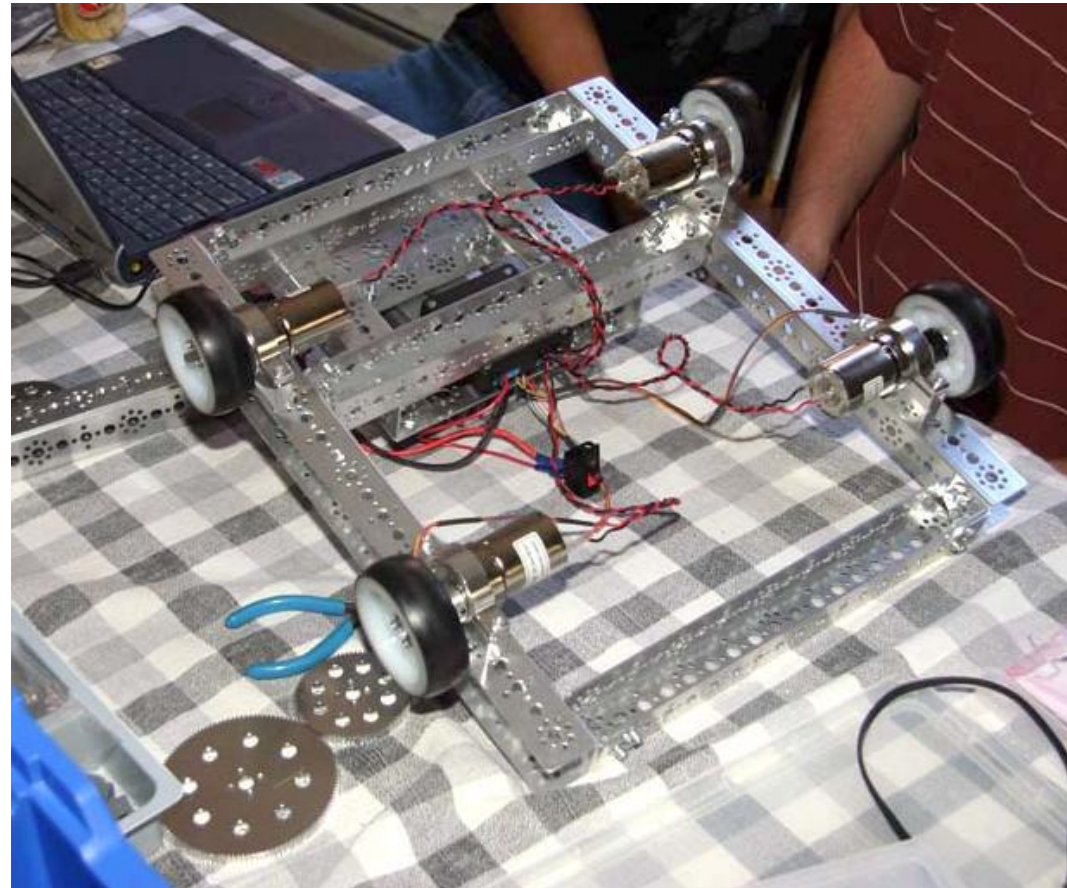

Design & Build - TETRIX Chassis Wheels and axles

- Axles are best supported on both sides
 - Brass axle bearings
 - If supported on only one end, keep axle short
 - Shaft collars lack stability when used alone
 - Nylon spacers enhance stability
- 4 or 6 wheel configurations
 - 6 wheel - shift mid wheels down slightly for better pivoting
- Taller wheels climb steps better
 - Extend wheels beyond chassis edge to improve climbing ability

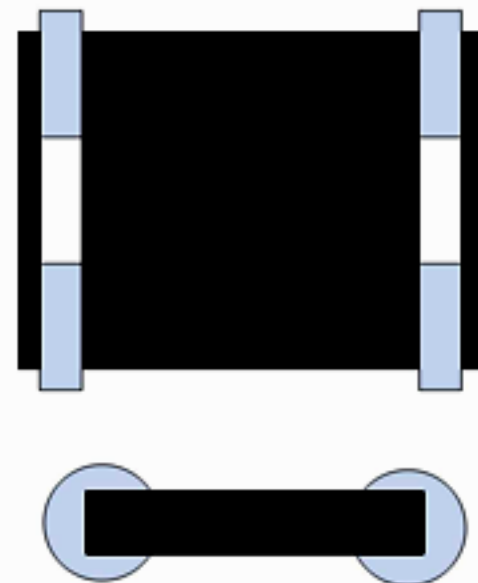

Design & Build - TETRIX Chassis

Power systems

- One 12 volt NiMH rechargeable battery pack, fused
 - Order spare batteries
- Powers all the secondary non-LEGO systems
- Charge at lower rate only!

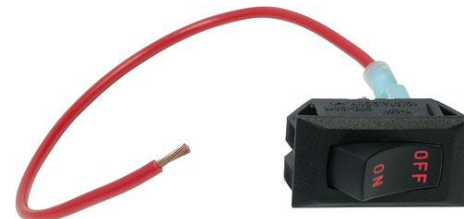

Dedication 1st D	Tellurium 52 Te	Iodine 53 I	Massachusetts 6th M	Lithium 3 Li	Nitrogen 7 N	Uranium 92 U	Americium 95 Am	Tellurium 52 Te	FIRSTium Gracious 1 I	Technetium 43 Tc	Fluorine 9 F
unlimited, syranweb.org	127.60	126.9	Sharon Eagle Robotics Assoc.	6.941	14.007	238.03	[243]	127.60	Professionalism	[98]	18.998



Design & Build - TETRIX Chassis

TETRIX power packs (rechargeable)

- Must use NiMH battery packs during competitions
- Should use freshly-charged batteries to compete
- Extra charged battery packs are key
 - Label date put in service, tag charged/not charged
- Voltage draw-down can cause microcontroller to reset
 - Can restart in autonomous mode, no remote control
- More weight/more motors drain batteries more quickly
- Make sure that you obtain spare fuses (auto supply)

Dedication 1st D unlimited, syranweb.org	Tellurium 52 Te 127.60	Iodine 53 I 126.9	Massachusetts 6th M Sharon Eagle Robotics Assoc.	Lithium 3 Li 6.941	Nitrogen 7 N 14.007	Uranium 92 U 238.03	Americium 95 Am [243]	Tellurium 52 Te 127.60	FIRSTium gracious 1 Professionalism	Technetium 43 Tc [98]	Fluorine 9 F 18.998
--	---------------------------------	----------------------------	--	-----------------------------	------------------------------	------------------------------	--------------------------------	---------------------------------	--	--------------------------------	------------------------------



Design & Build - TETRIX Chassis Examples from Team Unlimited robot

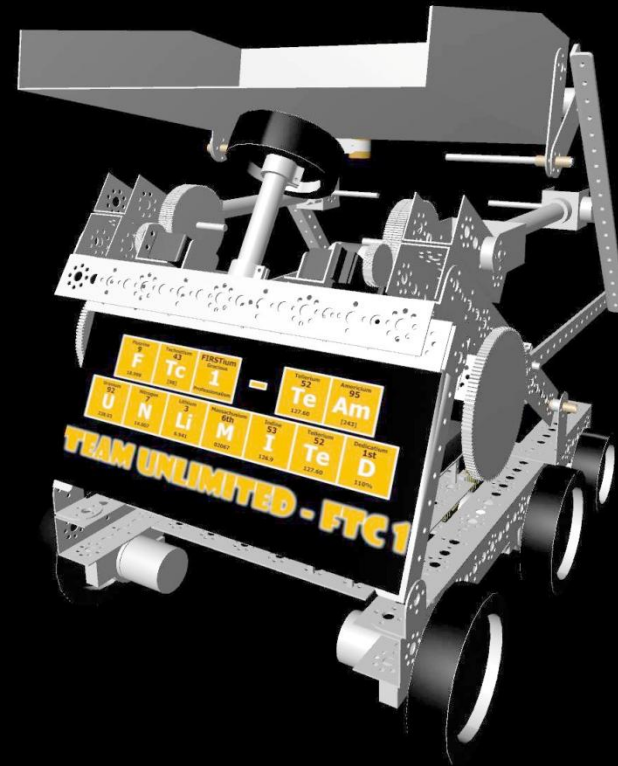
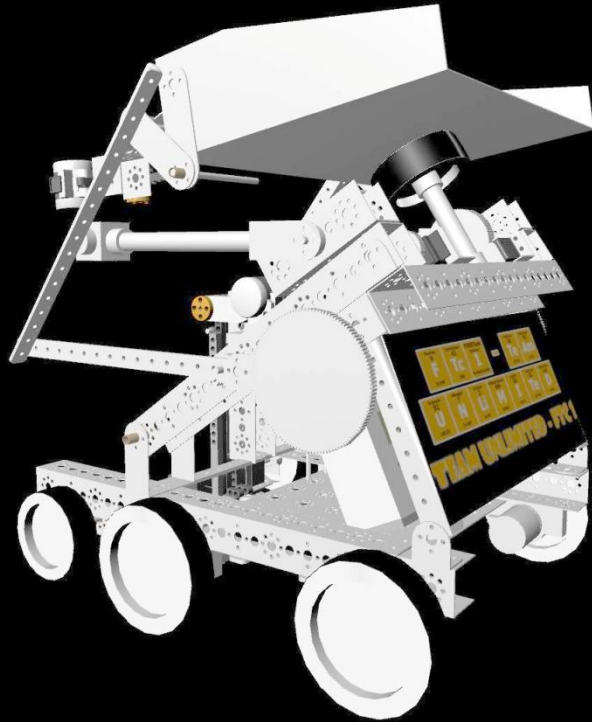

Fluorine 9 F 18.998	Technetium 43 Tc [98]	FIRSTium Gracious Professionalism 1	Tellurium 52 Te 127.60	Americium 95 Am [243]	Uranium 92 U 238.03	Nitrogen 7 N 14.007	Lithium 3 Li 6.941	Massachusetts 6th M Sharon Eagle Robotics Assoc.	Iodine 53 I 126.9	Tellurium 52 Te 127.60	Dedicatum 1st D unlimited, syranweb.org
------------------------------	--------------------------------	--	---------------------------------	--------------------------------	------------------------------	------------------------------	-----------------------------	--	----------------------------	---------------------------------	---

Design & Build - TETRIX Chassis Examples from Team Unlimited robot

Ganged and Geared servomotors

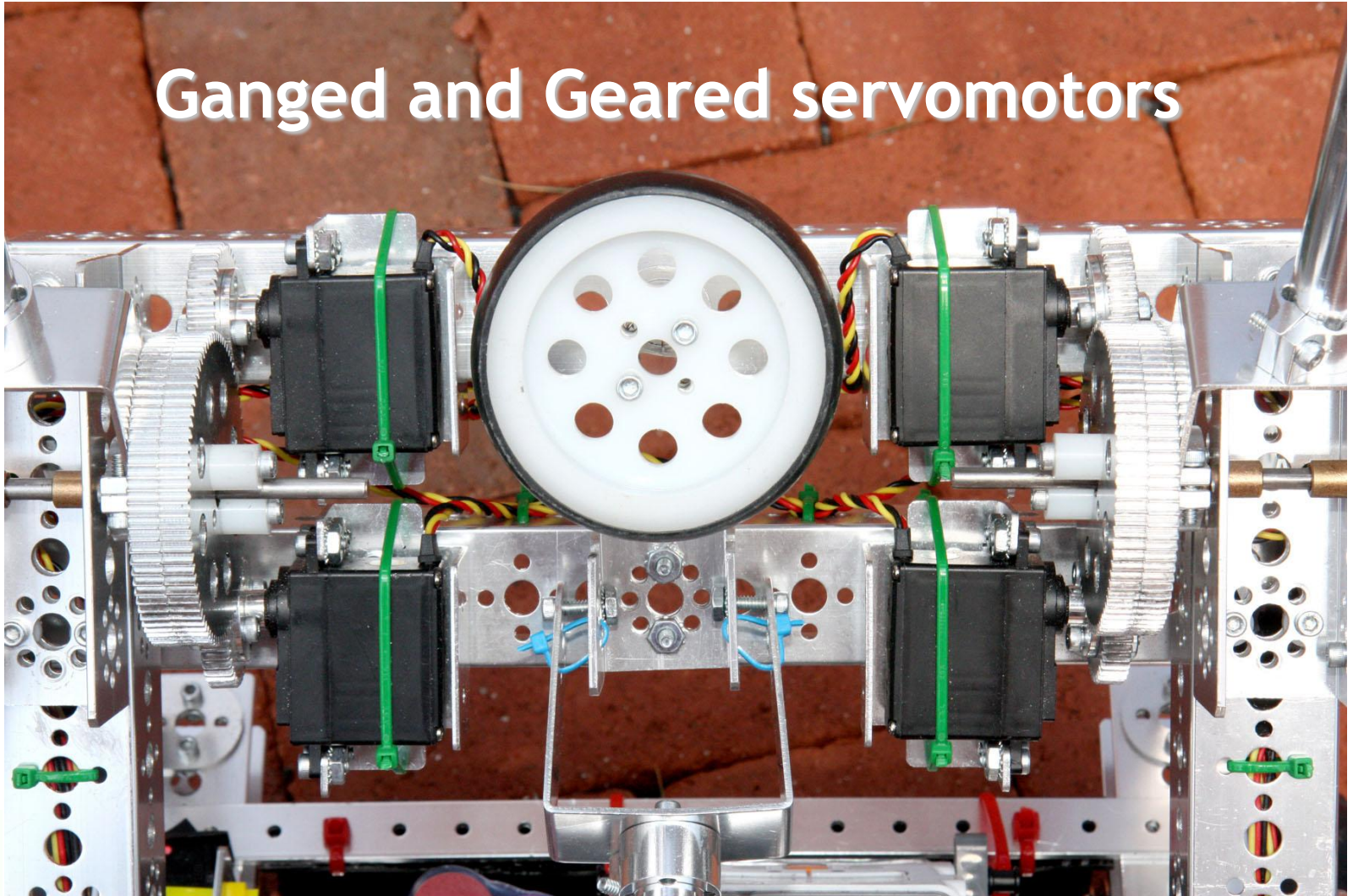

2012/13 Building for FTC with TETRIX - Hints and Tips Workshop



Dedication 1st D unlimited, syranweb.org	Tellurium 52 Te 127.60	Iodine 53 I 126.9	Massachusetts 6th M Sharon Eagle Robotics Assoc.	Lithium 3 Li 6.941	Nitrogen 7 N 14.007	Uranium 92 U 238.03	Americium 95 Am [243]	Tellurium 52 Te 127.60	FIRSTUM Gracious 1 Professionalism	Technetium 43 Tc [98]	Fluorine 9 F 18.998
--	---------------------------------	----------------------------	--	-----------------------------	------------------------------	------------------------------	--------------------------------	---------------------------------	---	--------------------------------	------------------------------

Design & Build - TETRIX Chassis Examples from Team Unlimited robot

Dedication 1st D unlimited, syranweb.org	Tellurium 52 Te 127.60	Iodine 53 I 126.9	Massachusetts 6th M Sharon Eagle Robotics Assoc.	Lithium 3 Li 6.941	Nitrogen 7 N 14.007	Uranium 92 U 238.03	Americium 95 Am [243]	Tellurium 52 Te 127.60	FIRSTium Gracious I Professionalism	Technetium 43 Tc [98]	Fluorine 9 F 18.998
--	---------------------------------	----------------------------	--	-----------------------------	------------------------------	------------------------------	--------------------------------	---------------------------------	--	--------------------------------	------------------------------

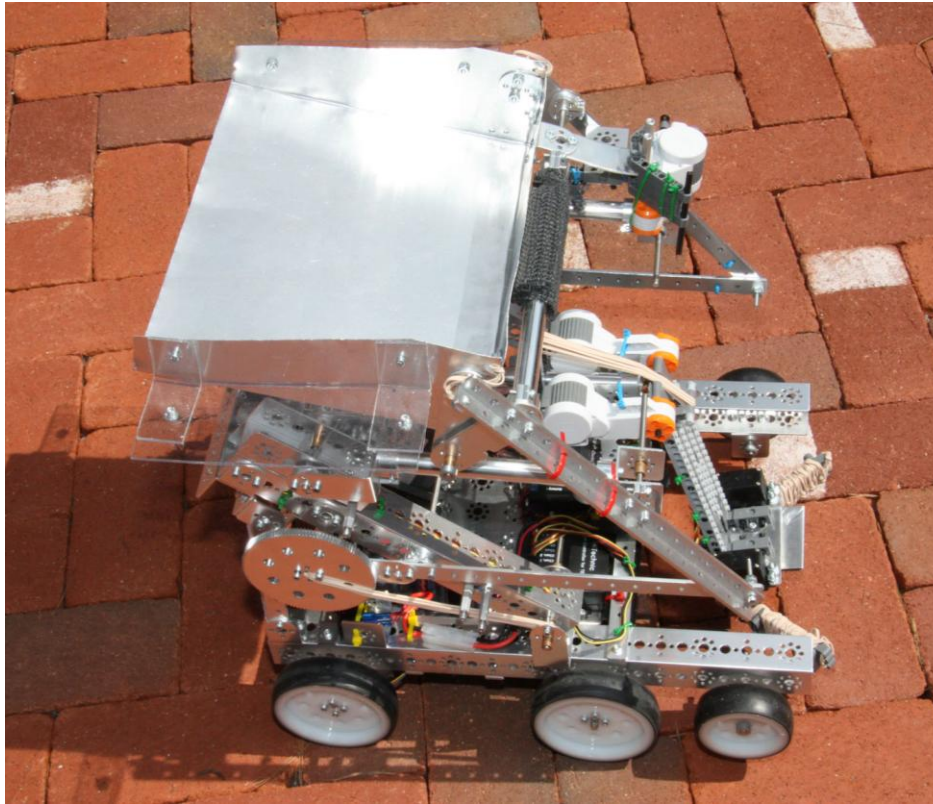

Lifting platform expanding
beyond 18" cube



Design & Build - TETRIX Chassis

Structural design

- Create modular structures
 - left and right drive-trains mirror images
- Don't maximize to 18" cube design early
 - Leave room for inevitable add-on pieces
 - Must fit in the inspection test box!
- Clearance
 - Game elements under your chassis can be disabling
 - Side guards and/or high clearance
- Defensive bumpers and guards
- CAD software is valuable for both design and documentation
 - PTC Creo/PRO (free from PTC!)
 - We have also used MS Visio and Autodesk MAYA



Design & Build - TETRIX Chassis

Structural design

- Gearing and power decisions
 - Balance speed v. torque
 - Increase speed by gearing up or adding motors
 - Limit gear ratio to 3:2, avoid motor damage
 - Increase torque by gearing down or adding motors
 - Middle ground, direct drive with a gear motor on each wheel
- Motor comparisons
 - Gearmotors are powerful, propulsion and heavy lifting
 - Use separate motor encoder as rotation sensor
 - Servomotors are less powerful but offer precise control
 - 180 degree throw (control angle) or continuous rotation (control speed)
 - LEGO motors are less powerful
 - NXT motor has integrated rotation sensor



Design & Build - TETRIX

Structural design

- Planning - what do you want to achieve and how will you achieve it?
- Design iteration
 - Brainstorm (what to build)
 - Design (how to build it)
 - Build it!
 - Test it!
 - Repeat until it's perfect (or good enough)
- Trade-offs: Good, Quick, Cheap - pick two (at most!)
 - Quality - Schedule - Budget
- Order parts for final assembly with plenty of lead time
 - Rush shipped from LEGO Education is expensive!



Design & Build - TETRIX

Structural design

- Murphy's Law (and its many corollaries)
 - Whatever can go wrong will go wrong, and at the worst possible time, in the worst possible way
 - Murphy was an optimist!
- Testing
 - Build at least a half-field if you don't have regular access to a regulation field
 - Backup strategies - alternatives if mechanical failure or opposing alliance counters
 - Anticipate points of failure
 - Spares kit and tools close by in competition
 - Design for easy access - ease of repair
 - Build sparring robot and participate in scrimmages



Design & Build - TETRIX

Structural design

- Trade-offs: Good, Quick, Cheap - pick two (at most)!
 - Quality - Schedule - Budget
- Robot speed - quick on field v. precision motion
- Robot complexity - simplicity v. capability
- Think Defensibly!
 - Protect vulnerable areas - contact sport
 - Guard wheel (and support both sides) - bumpers?
 - Protect all critical components while maintaining access
 - NXT, Samantha module, motor controllers, wires (through channels?), chains, switches . . .

Dedication 1st D unlimited, syranweb.org	Tellurium 52 Te 127.60	Iodine 53 I 126.9	Massachusetts 6th M Sharon Eagle Robotics Assoc.	Lithium 3 Li 6.941	Nitrogen 7 N 14.007	Uranium 92 U 238.03	Americium 95 Am [243]	Tellurium 52 Te 127.60	FIRSTium Gracious I Professionalism	Technetium 43 Tc [98]	Fluorine 9 F 18.998
--	---------------------------------	----------------------------	--	-----------------------------	------------------------------	------------------------------	--------------------------------	---------------------------------	--	--------------------------------	------------------------------



Design & Build - TETRIX

Structural design

- Prototyping
 - Avoid cutting structural materials early on
 - Measure once, cut twice - it's still too short!
 - Use simple sheet materials (cardboard, foamboard) to test concepts, can be used as a template later
- Keep important structures accessible for repair
- Do not use thread locker until design is stable
 - Loctite Blue, can be removed w/o heat application
- Replacement stainless steel screws are best!
- Nylox nuts are more secure
- Tape and glue are now legal
 - Team Duct Tape should be pleased!



Design & Build - TETRIX Chassis Navigation

- Sensors v. dead reckoning in autonomous mode
 - Timed movement inherently inaccurate
 - Motor encoders more precise, for measured motion & turns
 - Gyro sensor can yield accurate turns
 - Line following can help navigation
 - Touch and ultrasonic sensors can indicate position
- Remember - 3 other robots are on the field, and movement of field elements is not always predictable!
- Driver teams need practice!
 - Second robot chassis for driver drills and sparring partner

Dedication 1st D	Tellurium 52 Te	Iodine 53 I	Massachusetts 6th M	Lithium 3 Li	Nitrogen 7 N	Uranium 92 U	Americium 95 Am	Tellurium 52 Te	FIRSTium gracious 1 I	Technetium 43 Tc	Fluorine 9 F
unlimited, syranweb.org	127.60	126.9	Sharon Eagle Robotics Assoc.	6.941	14.007	238.03	[243]	127.60	Professionalism	[98]	18.998



Design & Build - TETRIX Manipulators

C.O.G. - Center of Gravity

- Robot that reach high, alter their center of gravity as they do
- Variable weights, variable angles of floor (ramp, step) and manipulator
- Aluminum components can reduce the manipulator weight
- If robot can turn over, useful to have a manipulator that can be used to right the robot

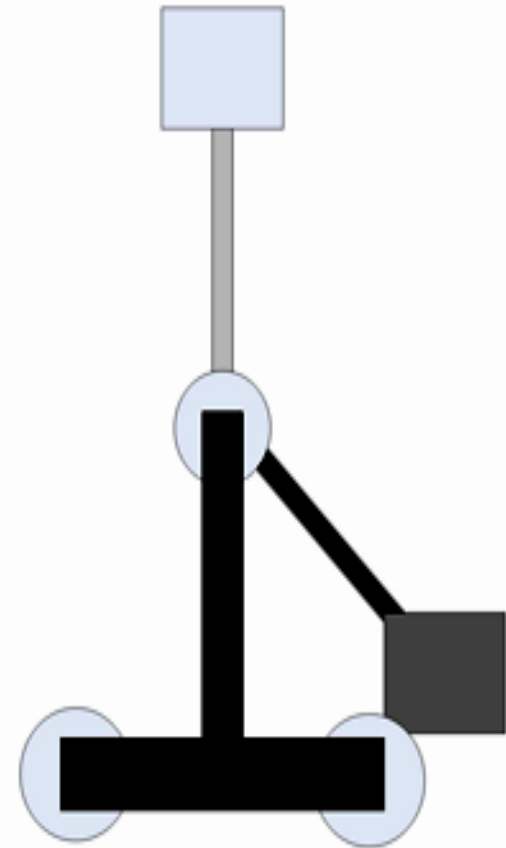

Design & Build - TETRIX Manipulators

Various designs

- Lifting mechanisms (can be combined)
 - Sliding/telescoping arms
 - Pivoting lever arms
 - Articulated arms
 - Conveyer rollers/belts
 - Scissors lifts
- Grasping mechanisms
 - Claws/clamps
 - Scoops/baskets
 - Brushes

Dedication 1st D unlimited, syranweb.org	Tellurium 52 Te 127.60	Iodine 53 I 126.9	Massachusetts 6th M Sharon Eagle Robotics Assoc.	Lithium 3 Li 6.941	Nitrogen 7 N 14.007	Uranium 92 U 238.03	Americium 95 Am [243]	Tellurium 52 Te 127.60	FIRSTium Gracious I Professionalism	Technetium 43 Tc [98]	Fluorine 9 F 18.998
--	---------------------------------	----------------------------	--	-----------------------------	------------------------------	------------------------------	--------------------------------	---------------------------------	--	--------------------------------	------------------------------



Design & Build - manipulators

Design criteria

- So far, challenges have manipulated balls, rings, pucks, batons . . .
 - Of various sizes (usually, larger is worth more)
 - To various heights (usually, higher is worth more)
- Also, lifting robot to bar (“hanging”)
- Critical issues - all interrelated
 - Center of Gravity (COG)
 - Moment arm
 - Length and height of reach
 - Load capacity

Dedication 1st D unlimited, syracuse.org	Tellurium 52 Te 127.60	Iodine 53 I 126.9	Massachusetts 6th M Sharon Eagle Robotics Assoc.	Lithium 3 Li 6.941	Nitrogen 7 N 14.007	Uranium 92 U 238.03	Americium 95 Am [243]	Tellurium 52 Te 127.60	FIRSTium Gracious I Professionalism	Technetium 43 Tc [98]	Fluorine 9 F 18.998
--	---------------------------------	----------------------------	--	-----------------------------	------------------------------	------------------------------	--------------------------------	---------------------------------	--	--------------------------------	------------------------------



Design & Build - manipulators

Design options

- Pivoting arms
 - Multiple stages of gearing?
 - Counter-weights?
 - Tension (rubber bands, surgical tubing)?
- Lifts
 - Extension (slide/telescope)
 - Scissors
- Grippers (grabbing or gathering)
 - Plows/scoops
 - Conveyor belts (treads)
 - Grasping mechanism

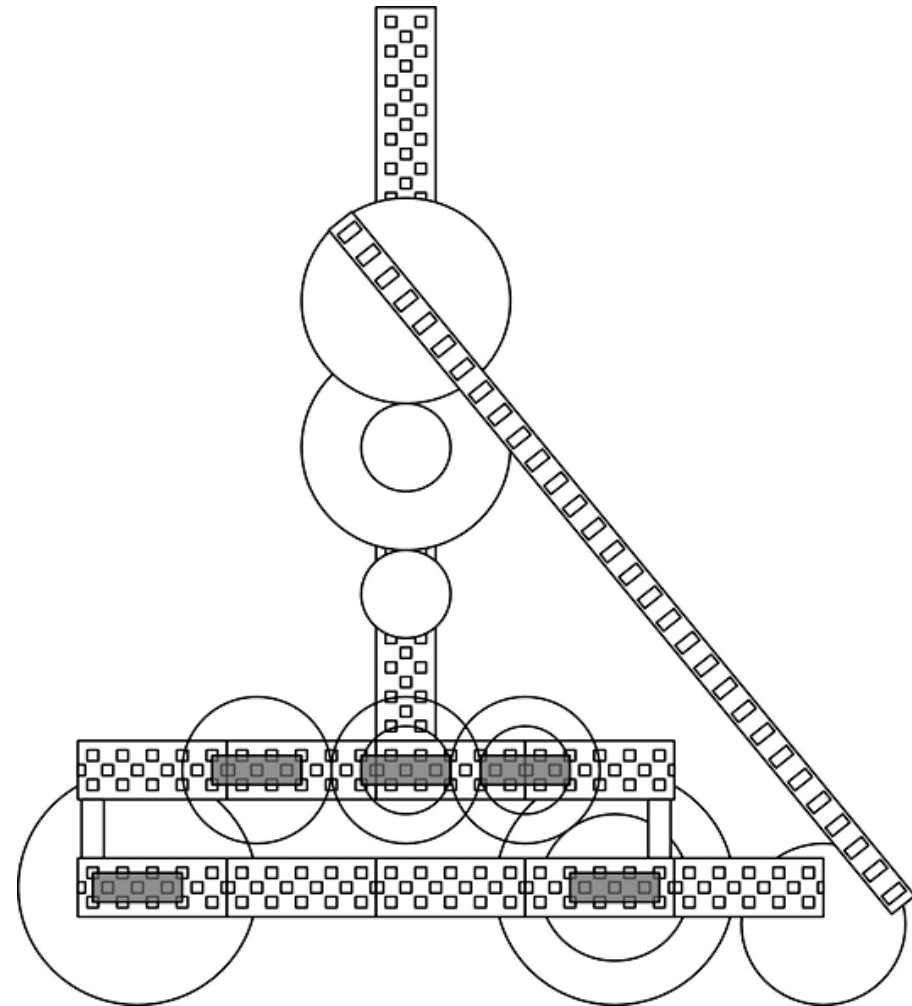

Design & Build - Ideas for robot design

- Feel free to mine our archival pages for photos of previous competitions - thousands of photos of teams and robots from competitions back to the first FVC demonstration (spring 2005).
- <http://www.ftc0001.org/SeasonsPast.htm>
- In various seasons, competitions from MA, RI, CT, NJ, and close-up photos from 3 FTC World Championships
 - **Field competition from ring-side!**

Dedication 1st D	Tellurium 52 Te	Iodine 53 I	Massachusetts 6th M <small>Sharon Eagle Robotics Assoc.</small>	Lithium 3 Li	Nitrogen 7 N	Uranium 92 U	Americium 95 Am <small>[243]</small>	Tellurium 52 Te <small>127.60</small>	FIRSTium Gracious 1 <small>Professionalism</small>	Technetium 43 Tc <small>[98]</small>	Fluorine 9 F <small>18.998</small>
------------------------	-----------------------	-------------------	--	--------------------	--------------------	--------------------	---	--	---	---	---



Design & Build - LEGO sub-systems

- LEGO NXT Education kit is included with the full version of the FTC TETRIX competition kit
 - Can use any non-electric LEGO components that are not specifically limited (including pneumatics), as many as you like



Design & Build - LEGO sub-systems Mindstorms NXT

Dedication 1st D unlimited, syranweb.org	Tellurium 52 Te 127.60	Iodine 53 I 126.9	Massachusetts 6th M Sharon Eagle Robotics Assoc.	Lithium 3 Li 6.941	Nitrogen 7 N 14.007	Uranium 92 U 238.03	Americium 95 Am [243]	Tellurium 52 Te 127.60	FIRSTium Gracious I Professionalism	Technetium 43 Tc [98]	Fluorine 9 F 18.998
--	---------------------------------	----------------------------	--	-----------------------------	------------------------------	------------------------------	--------------------------------	---------------------------------	--	--------------------------------	------------------------------

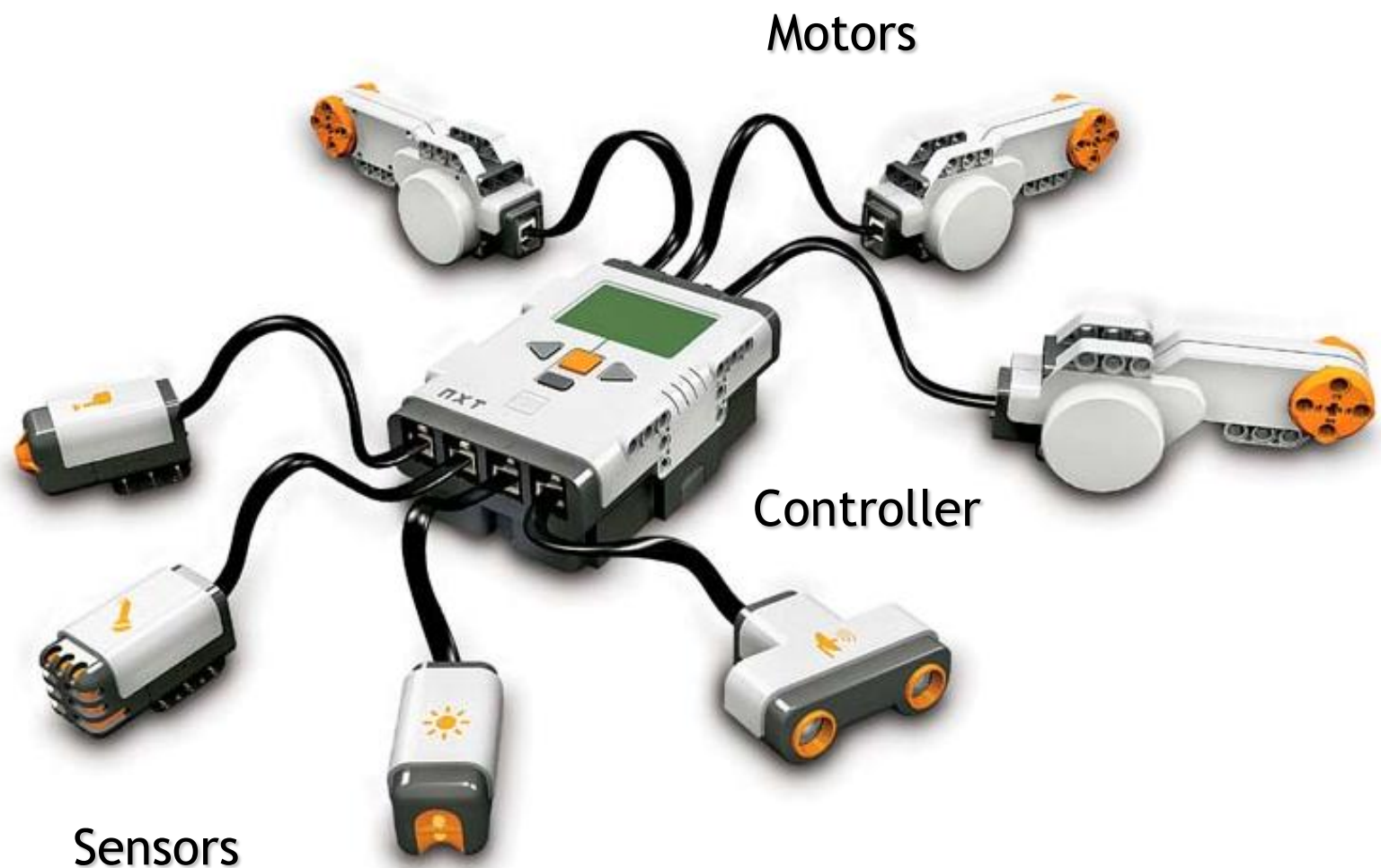

Motors

Controller

Sensors



Design & Build - LEGO sub-systems

TETRIX to LEGO connections

- Special LEGO components allow for the mounting of LEGO components to the TETRIX metals
 - NXT and motor controllers
 - Beams, et al (especially for manipulators)



Robot systems - NXT Controller

- Sensor ports - four input ports to attach sensors - 1, 2, 3 & 4.
- Motor ports - 3 output ports to attach motors - A, B & C
- USB port - for code loading
- NXT Buttons
Orange button : On/Enter /Run
Light grey arrows: Used to move left & right in the NXT menu
Dark grey button: Clear/Go back
- LEGO attachment points
- Loudspeaker

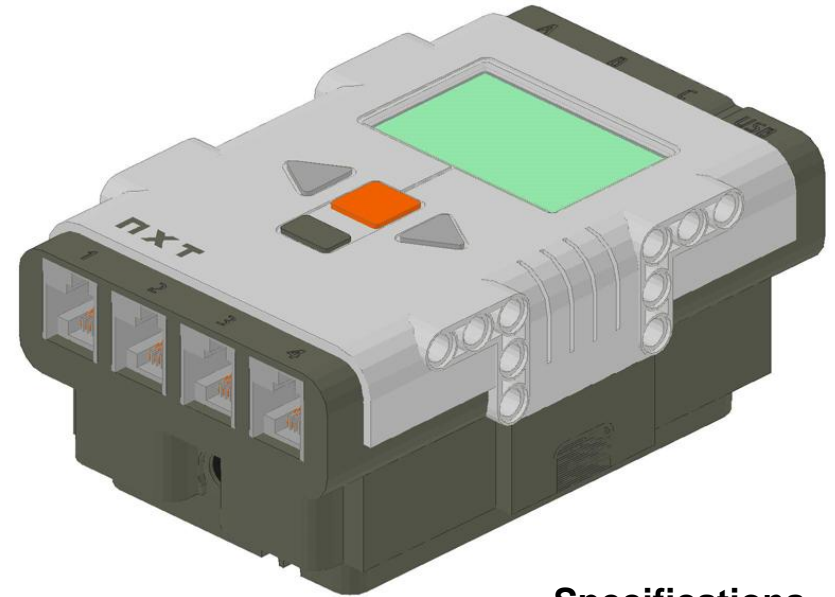

Specifications

32-bit ARM7 microcontroller
256 Kbytes FLASH, 64 Kbytes RAM
8-bit AVR microcontroller
4 Kbytes FLASH, 512 Byte RAM
Bluetooth wireless (Class II V2.0)
USB full speed port (12 Mbit/s)
4 input ports, 6-wire cable digital
3 output ports, 6-wire cable digital
100 x 64 pixel LCD graphical display
Loudspeaker - 8 kHz sound quality.
Power source: 6 AA batteries

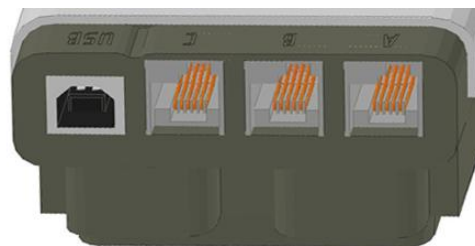

Design & Build - LEGO sub-systems

Mindstorms NXT motors

- Your robot is able to move using up to 3 servo motors.
- Turning speed is from 100-170 rpm
- NXT servo motors have an integrated rotation sensor.
- Two motors can be synchronized so that your robot will move in a straight line.

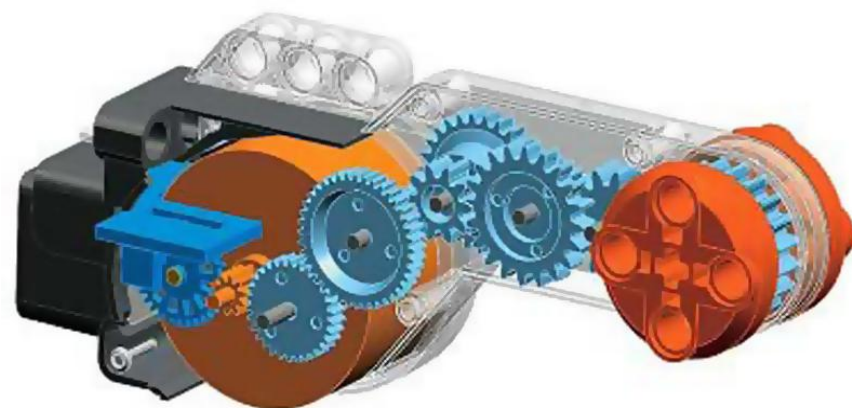
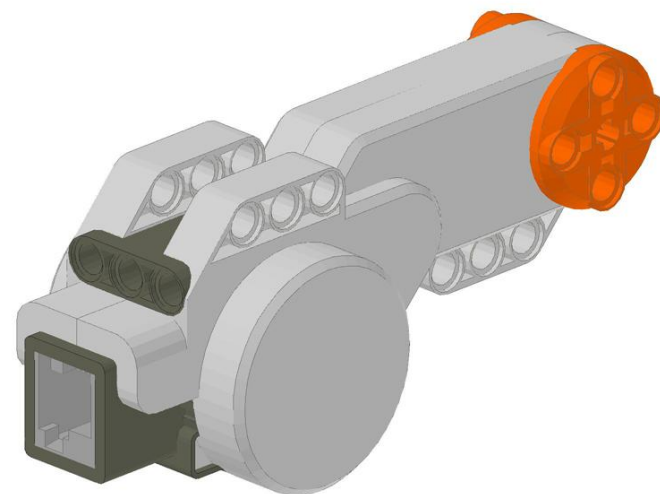

Design & Build - LEGO sub-systems

Additional Mindstorms NXT motors

- Additional LEGO motors are now allowed
 - Need adapter cables, no rotation sensor
- “Philo’s Home Page”
 - includes a thorough comparison of LEGO motors
 - <http://www.philohome.com/motors/motorcomp.htm>



**NXT motor
W979842**



**Power Functions
E motor
W979670**



**Power Functions
M motor
W978883**



**Power Functions
XL motor
W778882**



Design & Build - LEGO sub-systems

Mindstorms NXT power

- Batteries are placed inside of the NXT microcontroller
- 6 AA cells or 1 Lithium Ion rechargeable battery

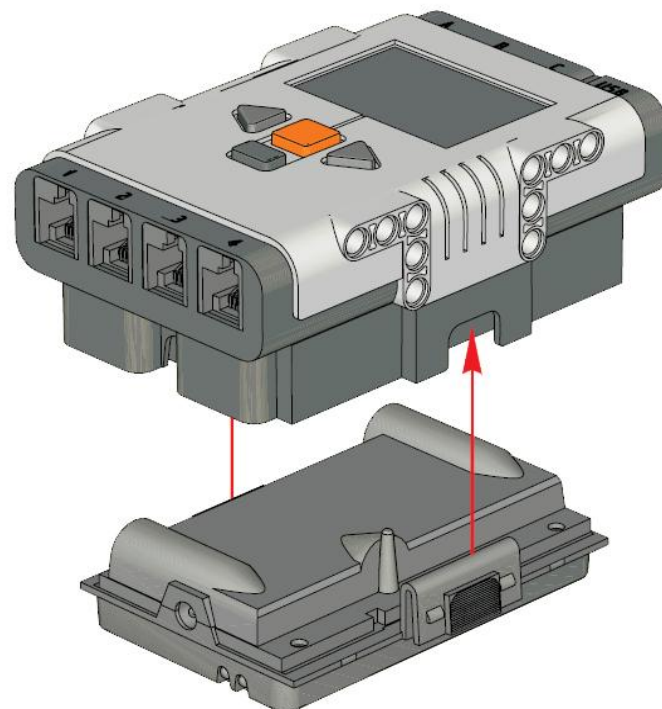

Robot systems - NXT sensors from LEGO

- Sensors are used to provide information about the environment to the microcontroller
- Provided by LEGO
 - light, color, touch, ultrasonic
- Provided by HiTechnic
 - Magnetic, gyro, accelerometer/tilt, IR seeker, angle

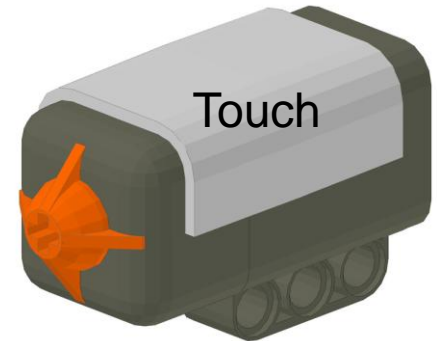
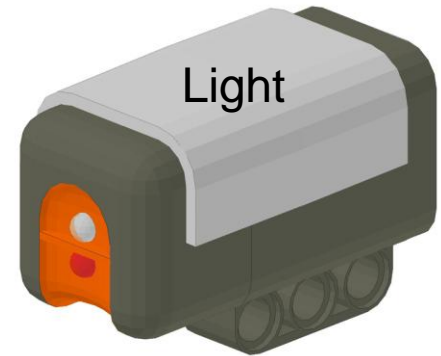

Robot systems - NXT sensors from HiTechnic



Dedication 1st D unlimited, syracuse.org	Tellurium 52 Te 127.60	Iodine 53 I 126.9	Massachusetts 6th M Sharon Eagle Robotics Assoc.	Lithium 3 Li 6.941	Nitrogen 7 N 14.007	Uranium 92 U 238.03	Americium 95 Am [243]	Tellurium 52 Te 127.60	FIRSTium Gracious 1 Professionalism	Technetium 43 Tc [98]	Fluorine 9 F 18.998
--	---------------------------------	----------------------------	--	-----------------------------	------------------------------	------------------------------	--------------------------------	---------------------------------	--	--------------------------------	------------------------------



Robot systems - NXT sensors

Touch Sensor Multiplexor

- Allows the connection of up to 4 touch sensors to the multiplexor, and then to a single NXT sensor port
 - Only works with touch sensors!

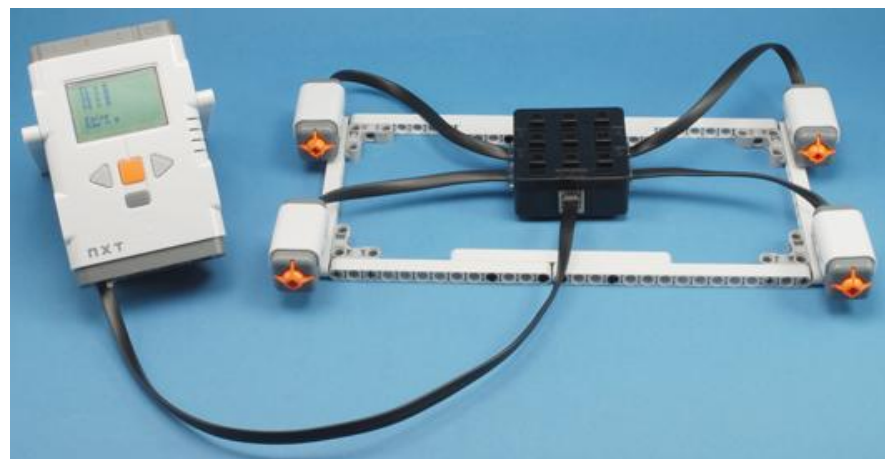

Robot systems - NXT sensors

Sensor Multiplexor

- Allows the connection of up to 4 of any sensors to the multiplexor, and then to a single NXT sensor port
- Powered by separate battery pack



2012/13 Building for FTC with TETRIS - Hints and Tips Workshop

Robot systems - NXT sensors

Rotation Sensor

- Rotation sensor
 - Use to measure motion of robot
 - Critical for accurate dead reckoning
 - Built into motors
 - Returns a logic signal to show rotation trigger
 - Senses above or below trigger point
 - Can read or reset values to zero
 - Can return current rotation reading (degrees or full turns)

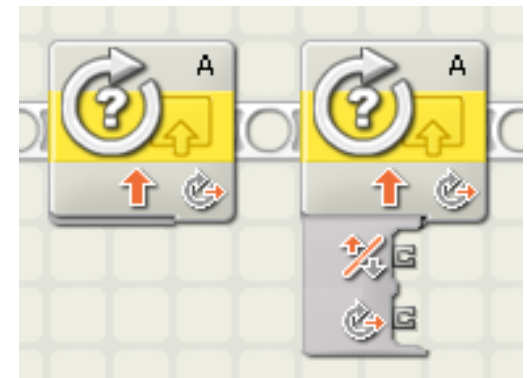
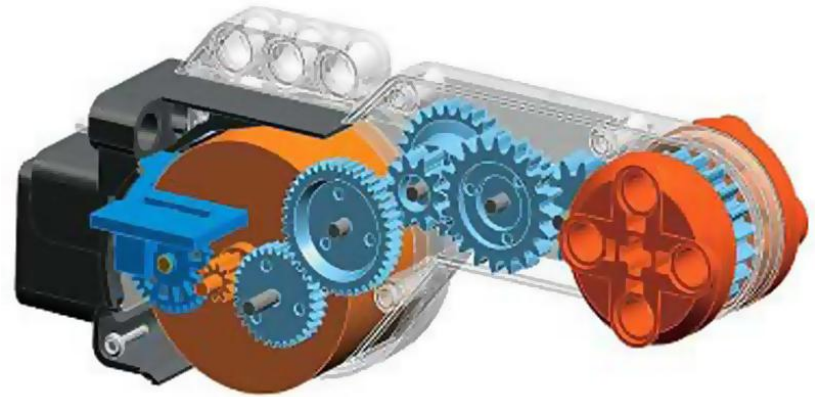

The FIRST Tech Challenge

- Competition is what ties the program together
- Motivation!
 - Failure of robotics kits in the retail marketplace
 - For **Inspiration** and **Recognition** of Science and Technology
- Our opportunity is to help move this program forward!
 - Promote the program at every opportunity!
 - Make the benefits available to every interested high school student!
 - And . . . encourage them to be interested!

To contact Team Unlimited:

website ftc0001.org email syraweb@comcast.net

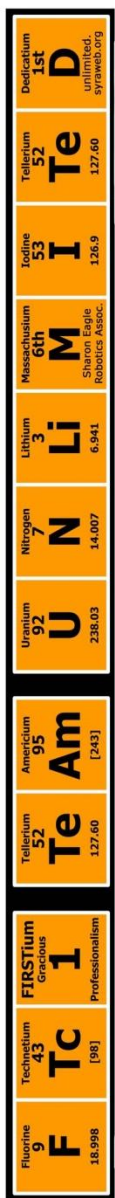

Fluorine 9 F 18.998	Technetium 43 Tc [98]	FIRSTium Gracious 1 Professionalism	Tellurium 52 Te 127.60	Americium 95 Am [243]	Uranium 92 U 238.03	Nitrogen 7 N 14.007	Lithium 3 Li 6.941	Massachusium 6th M Sharon Eagle Robotics Assoc.	Iodine 53 I 126.9	Tellurium 52 Te 127.60	Dedicatium 1st D unlimited. syraweb.org
-------------------------------------	---------------------------------------	--	--	---------------------------------------	-------------------------------------	-------------------------------------	------------------------------------	--	-----------------------------------	--	--

Designing for FTC with TETRIX Hints and Tips

Questions?

ftc0001.org



CAD - Computer Aided Design ProENGINEER from PTC

- PTC is now the official CAD and Collaboration sponsor for the FIRST Tech Challenge! They are providing free licenses of Pro/ENGINEER, MathCAD, & Windchill software to all FTC and FRC teams.
- Link to PTC resources at <http://unlimited.syraweb.org/PTC2009.htm>

The screenshot shows the PTC website interface. At the top, there is a navigation bar with the PTC logo and links for "United States", "Worldwide Sites", and "My Account". Below this is a search bar and a "Advanced Search" link. The main navigation menu includes "PRODUCTS", "SOLUTIONS", "SERVICES AND TRAINING", "RESOURCE CENTER", "ABOUT PTC", and "SUPPORT". The breadcrumb trail reads: "Home > About PTC > PTC Community and Education Programs > Education Program".

The main content area features a "DID YOU KNOW" box stating: "Engineers spend 60-80% of work time on design changes" with a "LEARN MORE" link. Below this is a "MORE INFORMATION" section.

2009 FRC and FTC - Getting Started Information

Quick Start Reference Guide
Getting Started Guide

This getting started guide will help you and your FRC & FTC teams understand and utilize the capabilities of Windchill ProjectLink for this season's competition. In addition, the guide will cover accessing, installing and utilizing Pro/ENGINEER (for CAD design) and Mathcad (for engineering calculations).

- Download the 2009 FRC and 2008 FTC Kit of Parts - www.ptc.com/go/firstkop

Resources for Windchill ProjectLink

- Windchill ProjectLink Datasheet
- Windchill 9.0 Help Center
- Windchill Manuals
- Using Pro/ENGINEER Wildfire with Windchill

Resources for Pro/ENGINEER

- Pro/ENGINEER Brochure
- Installation Guide (Pro/ENGINEER Schools Edition)
- Support Documentation
 - Pro/ENGINEER Wildfire 4.0 - Quick Reference Card
 - Pro/ENGINEER Schools Edition - FAQ
 - Troubleshooting - FAQ
 - Running Pro/ENGINEER on Microsoft Vista
 - Minimum System Requirements
- Basic Pro/ENGINEER Tutorials

Resources for Mathcad

- Mathcad Brochure
- Requesting a product code for Mathcad

Discussion Forums and Support

- FRC Discussion Forum
- FTC Discussion Forum
- Pro/ENGINEER Schools Edition Forum
- Email firstsupport@ptc.com for assistance with any of the provided PTC applications.

